



MODULAR CUBER

PARTS LIST

[HE] [GENERAL(60Hz)][KOREA]

E1CP

E1CP-D001, D002, D003, D004, D006, D007, D008, D009
-D010, D011, D012, D013, D014, D015, D016, D017
-D018, D019, D020, D021, D022

A-1 SEP. 2011
B-0 JAN. 2012
B-1 JUN. 2012
B-2 SEP. 2012
B-3 OCT. 2012
C-0 JAN. 2013
C-1 FEB. 2013
D-0 JAN. 2014
E-0 JAN. 2015

IM-240ANE
IM-240ANE-21
IM-240ANE-23
IM-240AWNE
IM-240AWNE-21
IM-240AWNE-23
IM-240AWNE-17

List of Specifications

IM-240ANE	E1CP	Standard
IM-240ANE-23	E1CP-D001	23mm ICE of IM-240ANE
IM-240ANE-21	E1CP-D002	21mm ICE of IM-240ANE
IM-240AWNE	E1CP-D003	Water cooled
IM-240AWNE-23	E1CP-D004	For HE,23mm ICE of IM-240AWNE
IM-240AWNE	E1CP-D006	230V,60Hz of IM-240AWNE
IM-240AWNE-23	E1CP-D007	For GENERAL 23mm ICE,230V,60Hz of IM-240AWNE
IM-240AWNE-21	E1CP-D008	For GENERAL 21mm ICE,230V,60Hz of IM-240AWNE
IM-240ANE	E1CP-D009	For GENERAL,230V,60Hz of IM-240ANE
IM-240AWNE-17	E1CP-D010	For KOREA 17mm ICE,220V,60Hz of IM-240AWNE
IM-240AWNE	E1CP-D011	SUS316 frame of IM-240AWNE
IM-240AWNE-21	E1CP-D012	For GENERAL, 21mm ICE,230V,60Hz, SUS316 frame of IM-240AWNE
IM-240ANE	E1CP-D013	SUS316 frame of IM-240ANE
IM-240ANE-23	E1CP-D014	23mm ICE,SUS316 frame of IM-240ANE
IM-240ANE-21	E1CP-D015	21mm ICE,SUS316 frame of IM-240ANE
IM-240AWNE-23	E1CP-D016	23mm ICE,SUS316 frame of IM-240AWNE
IM-240AWNE	E1CP-D017	For GENERAL 230V,60Hz,SUS316 frame of IM-240AWNE
IM-240AWNE-23	E1CP-D018	For GENERAL, 23mm ICE, 230V,60Hz, SUS316 frame of IM-240AWNE
IM-240ANE	E1CP-D019	For GENERAL 230V,60Hz,SUS316 frame of IM-240ANE
IM-240AWNE	E1CP-D020	For KOREA, 220V,60Hz of IM-240AWNE
IM-240AWNE-23	E1CP-D021	For KOREA 23mm ICE,220V,60Hz of IM-240AWNE
IM-240AWNE-21	E1CP-D022	For KOREA 21mm ICE,220V,60Hz of IM-240AWNE

AUXILIARY CODE

U - 1

The auxiliary code is the first two characters in the serial number. The first character indicates the production year. Years progress or regress in alphabetical order. The series of letters and skipped letters depend on UL listing, production, and model. See the auxiliary code(s) and corresponding year(s) on the front cover.

The second character indicates significant part changes within the same year. Base is "1" and this number advances for each change. If there is no significant part change at the turn of the year, this number starts from "0."

MARKS LOCATED UNDER THE AUXILIARY CODE

- = Part deleted.
- x = Part deleted and replaced by "o" part.
- o = New part in place of "x" part.

FASTENER PART NUMBER

SCREWS



^{*1} Material

- F: Steel
- S: Austenitic stainless steel
- M: Martensitic stainless steel
- B: Copper alloy
- P: Polycarbonate
- N: Polyamide
- V: PVC
- A: ABS
- X: Polyacetal
- L: Aluminum

NUTS & WASHERS

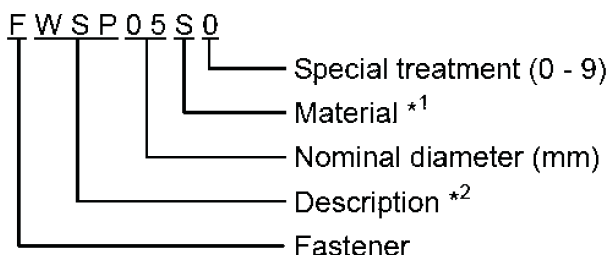

^{*2} Description

- First letter
- S: Machine screw
- T: Tapping screw
- M: Wood screw
- B: Bolt
- W: Washer
- N: Nut

IM-240ANE (-23)
IM-240AWNE (-21, -23, -23)

50Hz (A-1) to (B-0)
60Hz (A-1) to (C-0)

A. ICE CUBBER ASSY (1/2)

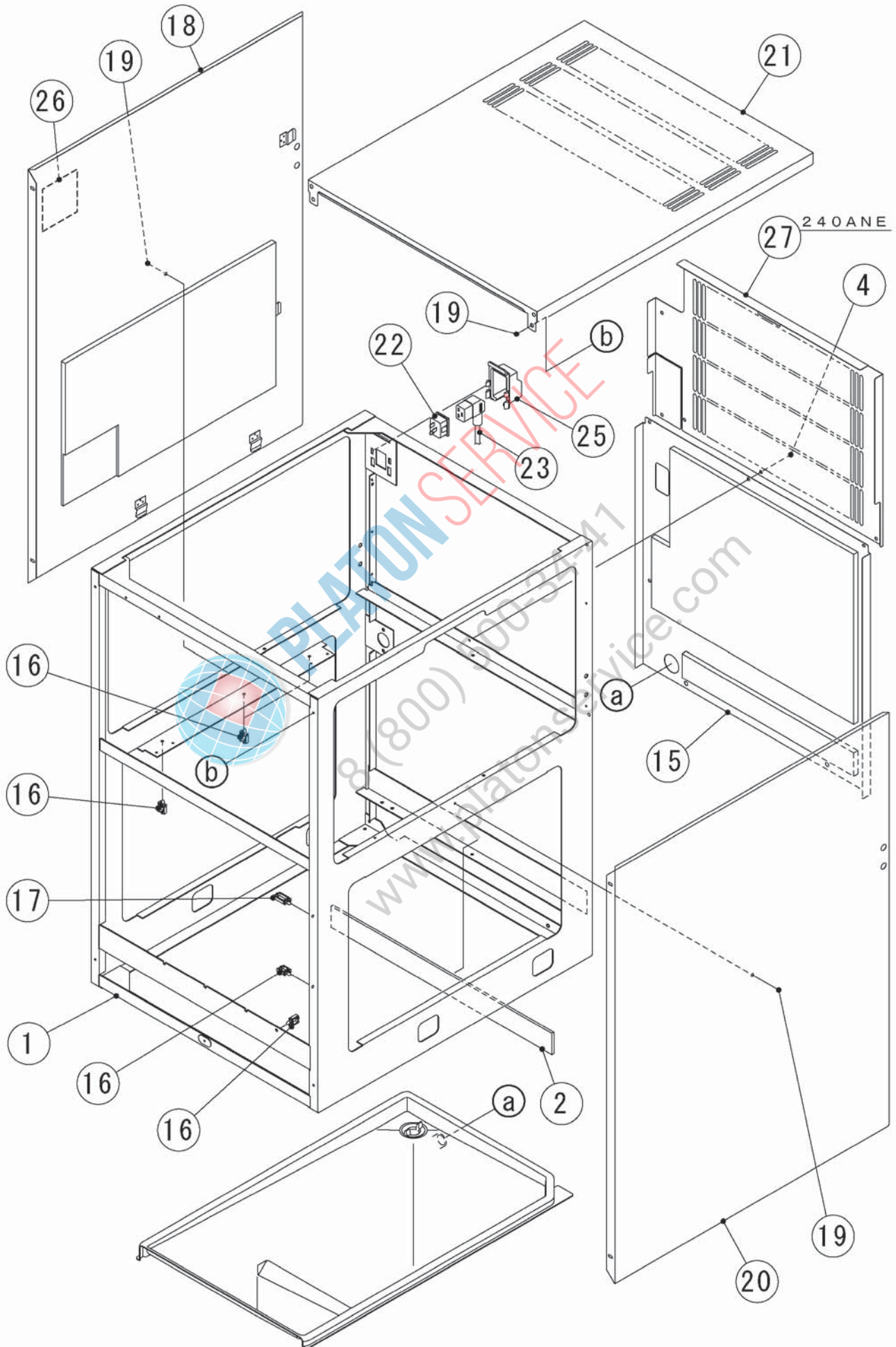

IM-240ANE (-23)
IM-240AWNE (-21, -23, -17)

50Hz (A-1) to (B-0)
60Hz (A-1) to (C-0)

A. ICE CUBBER ASSY (2/2)

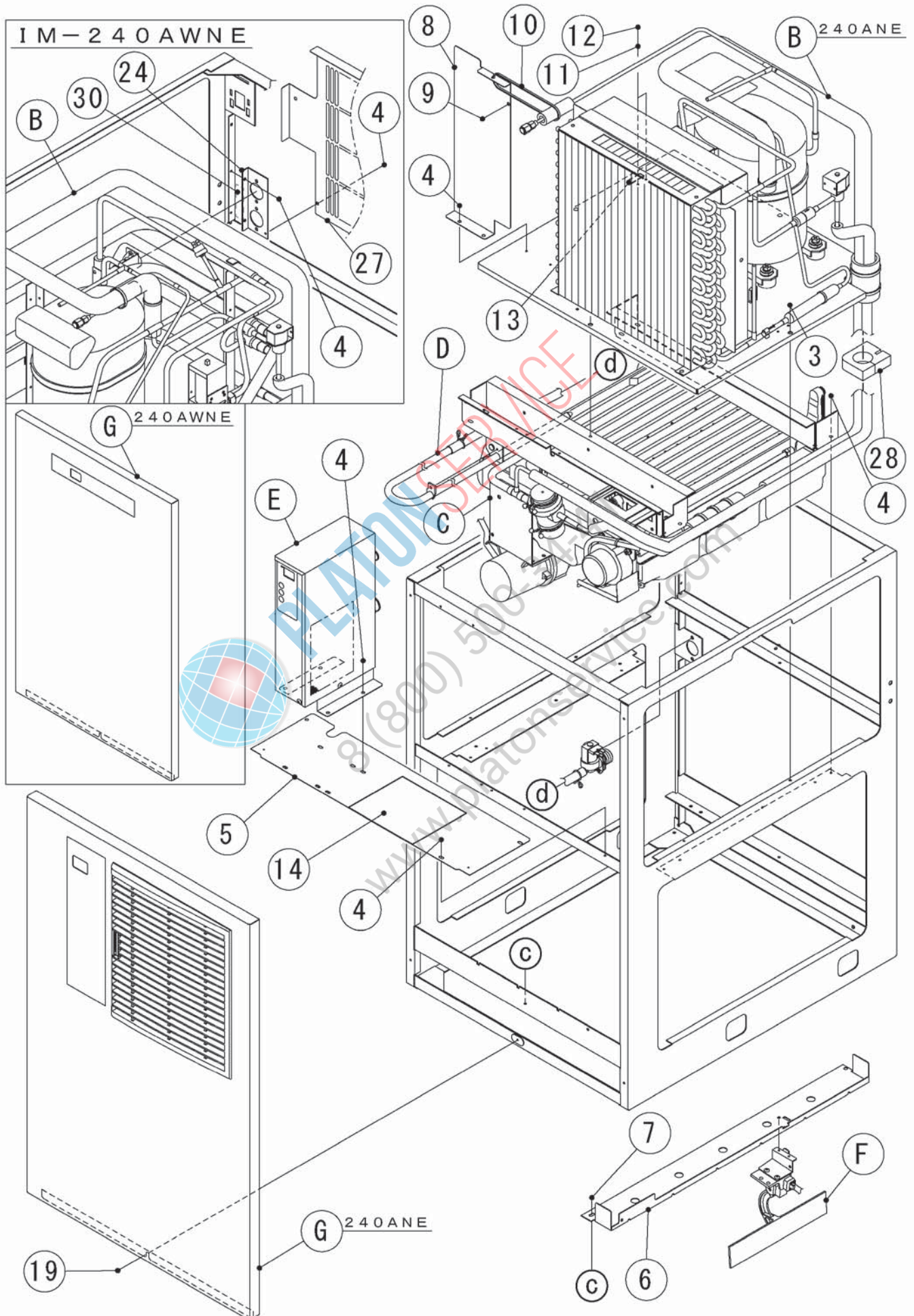

IM-240ANE (-21,-23)
IM-240AWNE (-21,-23,-17)

A. ICE CUBBER ASSY (1/2)

50Hz (B-1) and later
60Hz (C-1) and later

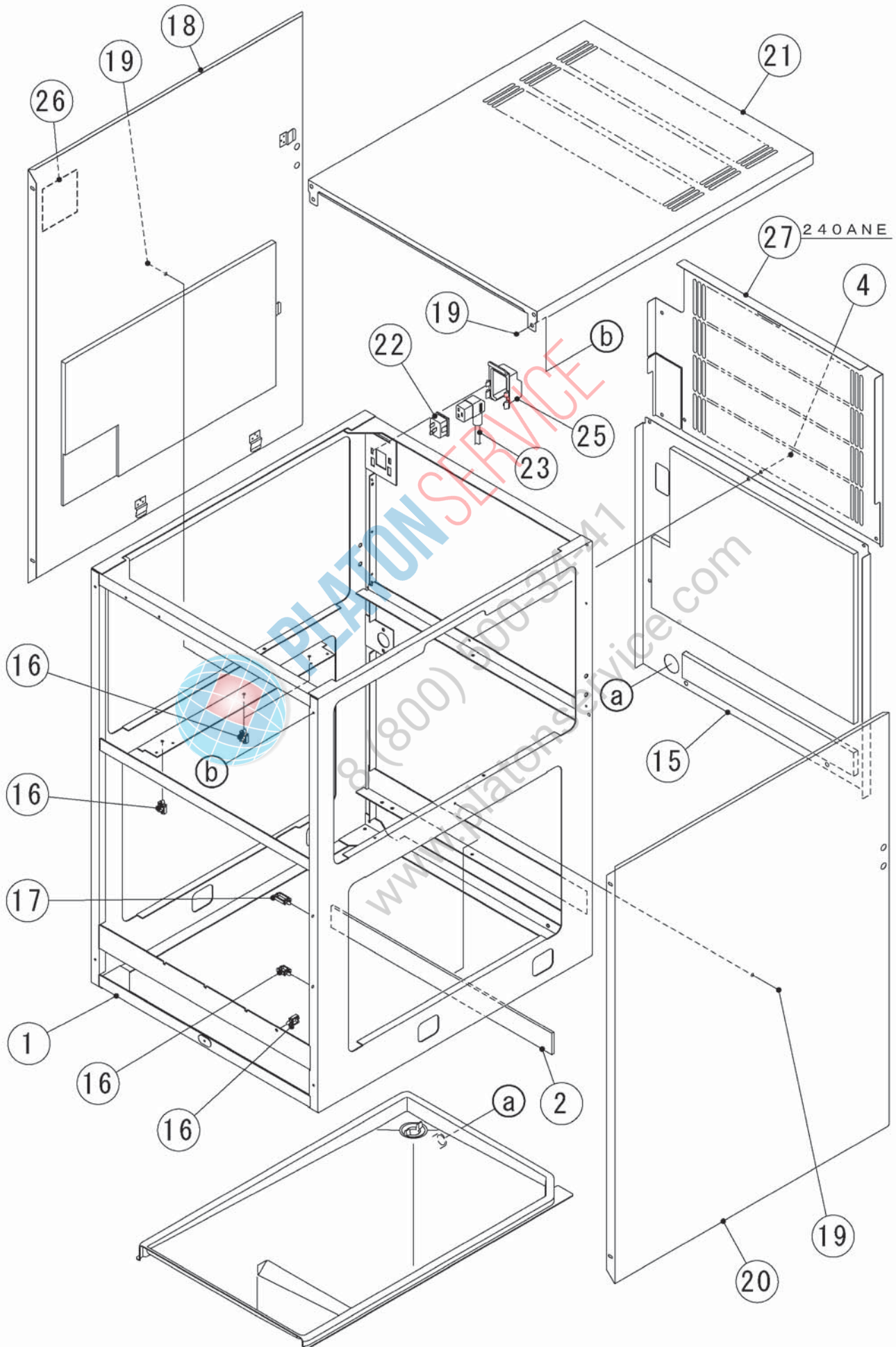

IM-240ANE (-21,-23)
IM-240AWNE(-21,-23,-17)

A. ICE CUBBER ASSY (2/2)

50Hz (B-1) and later
60Hz (C-1) and later

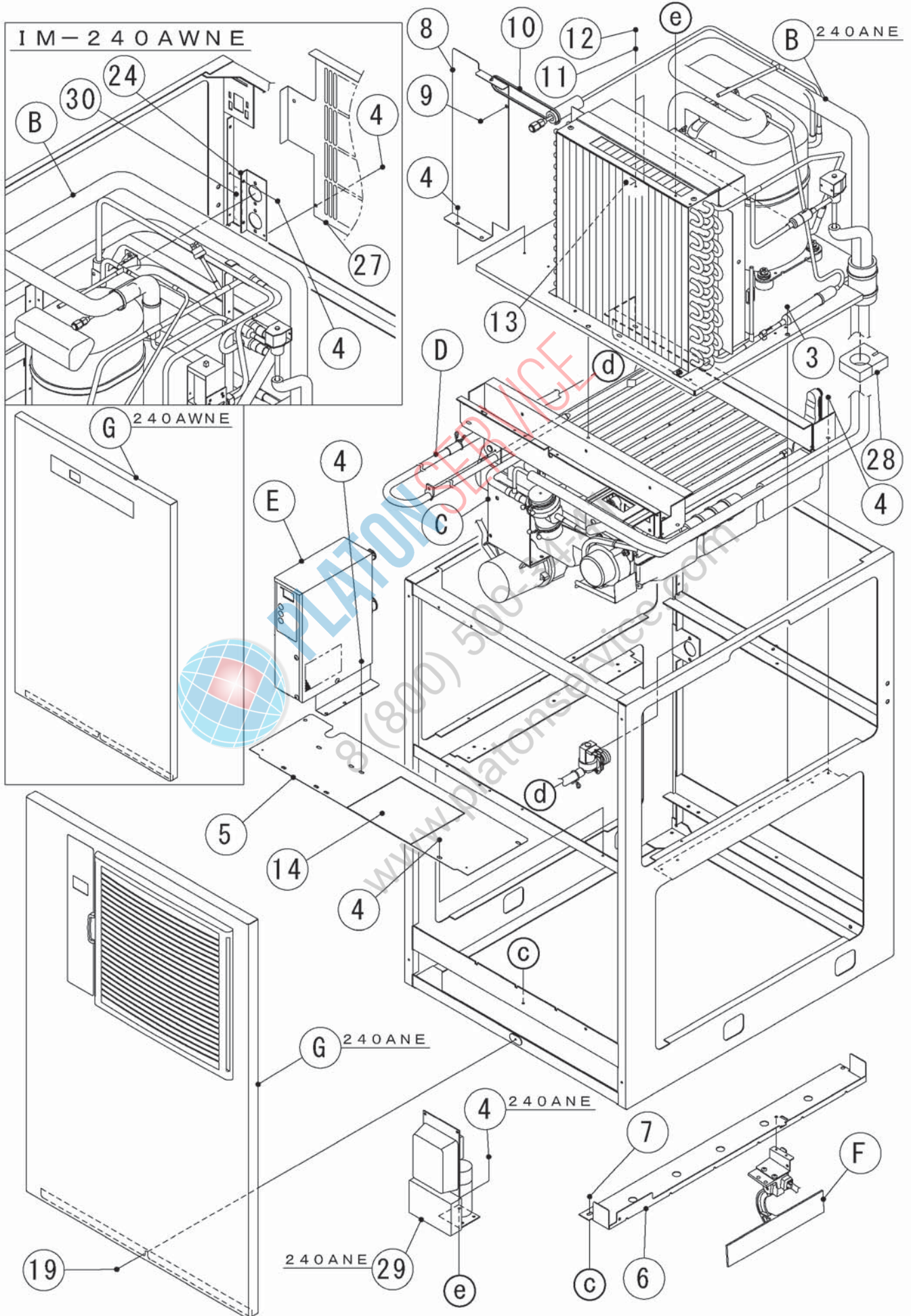

MODEL: IM-240ANE,-21,-23 IM-240AWNE,-21,-23,-17				TITLE: A.ICE CUBBER ASSY			
INDEX NO.	DESCRIPTION	MATERIAL OR MODEL NUMBER	PART NUMBER	REQ'D NUMBER			
				A-1 B-0	B-1 B-2	B-3 C-0	C-1,D-0 E-0,F-0
B	REFRIGERATION ASSY	(240ANE,-21,-23) (50Hz)	1H4741A01	1	-	-	-
		(240ANE)(60Hz)	1H5195A01	-	1	1	1
					-	-	-
		(240AWNE,-21,-23) (50Hz)	1H4792A01	1	-	-	-
			1H5206A01	-	1	1	1
		(240AWNE,-21,-23,-17) (60Hz)	1H4792A01	1	1	1	-
1H5206A01	-		-	-	1		
C	MECHANISM ASSY		1H4743A01	1	1	1	1
D	WATER CIRCUIT ASSY		2X0229A01	1	1	1	1
E	CONTROL BOX ASSY	(240ANE,-21,-23)	2X0231A01	1	-	-	-
			2X1197A01	-	1	1	1
		(240AWNE,-21,-23) (50Hz)	2X0353A01	1	-	-	-
			2X1197A02	-	1	1	1
		(240AWNE,-21,-23,-17) (60Hz)	2X0353A01	1	1	1	-
			2X1197A02	-	-	-	1
F	BIN SWITCH - 2 ASSY		3Y5468A01	1	1	1	1
G	FRONT COVER ASSY	(240ANE,-21,-23)	2X0240A01	1	-	-	-
			2X1201A01	-	1	1	1
		(240AWNE,-21,-23) (50Hz)	2X0358A01	1	-	-	-
			2X1241A01	-	1	1	1
		(240AWNE,-21,-23,-17) (60Hz)	2X0358A01	1	1	1	-
			2X1241A01	-	-	-	1
K	ACCESSORIES		A02335-01	1	1	1	1
L	OPTIONAL PARTS		OPT-E1CP	1	1	1	1
1	UNIT FRAME		1H4740G01	1	1	1	1
		(SUS316)	1H5537G01	-	-	-	1
2	INSULATION - FRAME (A)		4Y6982P01	1	1	1	1
3	HEX HEAD BOLT		FBK0620S0	4	4	4	4
	(SPRING WASHER AND FLAT WASHER)						
4	FLANGE BOLT (S-TITE)	(240ANE,-21,-23)	FTR0408M0	24	24	24	24
		(240AWNE,-21,-23)(50Hz)		25	27	27	27
		(240AWNE,-21,-23,-17)(60Hz)		25	25	25	27

HE,GENERAL,KOREA

MODEL: IM-240ANE,-21,-23 IM-240AWNE,-21,-23,-17				TITLE: A.ICE CUBBER ASSY			
INDEX NO.	DESCRIPTION	MATERIAL OR MODEL NUMBER	PART NUMBER	REQ'D NUMBER			
				A-1 B-0	B-1 B-2	B-3 C-0	C-1,D-0 E-0,F-0
5	COVER - FRAME	(50Hz)	4Y6913G01	1	-	-	-
			4Y7825G01	-	1	1	1
		(60Hz)	4Y6913G01	1	1	1	-
			4Y7825G01	-	-	-	1
6	FRAME - BIN SWITCH		3Y5348M01	1	1	1	1
7	HEX HEAD BOLT (SPRING WASHER AND FLAT WASHER)		FBK0508S0	2	2	2	2
8	PLATE - UNIT	(240ANE,-21,-23)	3Y5381M01	1	1	1	1
		(240ANE)(60Hz)	3Y7371M01	-	-	-	1
9	TRUSS HEAD TAPPING SCREW T2	(240ANE,-21,-23)	FT20408F0	1	1	1	1
10	TIE	(240ANE,-21,-23)	7920-0003	1	1	1	1
11	SPRING WASHER		FWSP04S0	2	2	2	2
12	TRUSS HEAD MACHINE SCREW		FST0408S0	2	2	2	2
13	LABEL - GROUND	(50Hz)	451712-01	1	-	-	-
	LABEL - GROUND (B)		450452-02	-	1	1	1
	LABEL - GROUND	(60Hz)	451712-01	1	1	1	-
	LABEL - GROUND (B)		450452-02	-	-	-	1
14	WIRING LABEL	(50Hz)	3Y5103L01	1	-	-	-
			3Y6692L01	-	1	1	1
		(60Hz)	3Y5103L01	1	1	1	-
			3Y6692L01	-	-	-	1
15	REAR PANEL		3Y5785G01	1	1	1	1
16	WIRE SADDLE		428060-03	5	5	5	5
17	WIRE SADDLE		428060-02	1	1	1	1
18	SIDE PANEL (L)		3Y5419G01	1	1	1	1
19	TRUSS HEAD TAPPING SCREW (S-TITE)		FTS0408M0	15	15	15	15
20	SIDE PANEL (R)		2X0281G01	1	1	1	1
21	TOP PANEL		2X0236M01	1	1	1	1
22	CONNECTOR		P00246-01	1	1	1	1
23	POWER SUPPLY CORD	EU-PLUG(16A)	P03362-01	1	1	1	1
		UK-PLUG(13A)	P03363-01	1	1	1	1
		AS-PLUG(15A)	P03364-01	1	1	1	1

HE,GENERAL,KOREA

MODEL: IM-240ANE,-21,-23 IM-240AWNE,-21,-23,-17				TITLE: A.ICE CUBBER ASSY			
INDEX NO.	DESCRIPTION	MATERIAL OR MODEL NUMBER	PART NUMBER	REQ'D NUMBER			
				A-1 B-0	B-1 B-2	B-3 C-0	C-1,D-0 E-0,F-0
24	BRACKET - FITTING	(240AWNE,-21,-23,-17)	4Y3072-01	1	1	1	1
25	COVER - CONNECTOR		2X0271P01	1	1	1	1
26	NAME PLATE		N/A	1	1	1	1
27	REAR PANEL UP	(240ANE,-21,-23)	2X0612M01	1	1	1	1
		(240AWNE,-21,-23,-17)	2X0613M01	1	1	1	1
28	INSULATION		4Y0306-01	1	1	1	1
29	STARTING DEVICE	(50Hz)	P01856-01	-	1	1	1
		(60Hz)	P02887-01	-	-	-	1
30	LABEL-CONNECTION	(240AWNE,-21,-23,-17)	464541-01	1	1	1	1



PLATON SERVICE
 8 (800) 500-34-47
www.platonservice.com

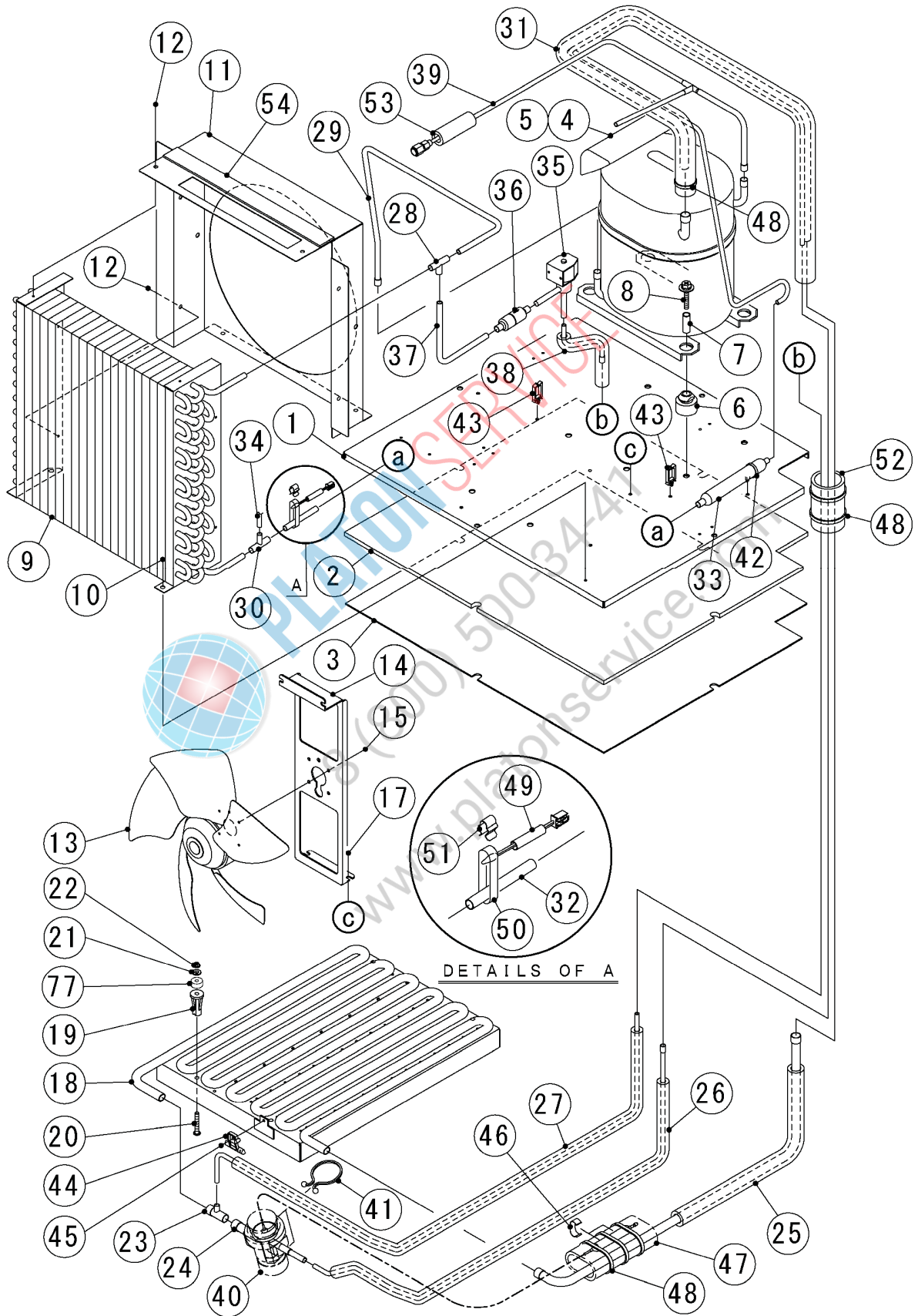

MODEL: IM-240ANE,-21,-23			TITLE: B.REFRIGERATION ASSY				
INDEX NO.	DESCRIPTION	MATERIAL OR MODEL NUMBER	PART NUMBER	REQ'D NUMBER			
				A-1 B-0	B-1 B-2	B-3 C-0	C-1,D-0 E-0,F-0
1	BASE		3Y5351G01	1	1	1	1
2	INSULATION - BASE		4Y6898P01	1	1	1	1
3	PLATE - BASE		4Y0249-01	1	1	1	1
4	COMPRESSOR		4A1581-01	1	-	-	-
			P01855-01	-	1	1	1
5	MOTOR PROTECTOR		4A1581F01	1	-	-	-
6	GROMMET		434922-02	4	-	-	-
	RUBBER GROMMET		P01858-01	-	4	4	4
7	SPACER		434921-01	4	-	-	-
	SLEEVE		P01859-01	-	4	4	4
8	BOLT		436206-04	4	-	-	-
			436206-03	-	4	4	4
9	CONDENSER		P03307-01	1	1	1	1
10	FLANGE BOLT (S-TITE)		FTR0408M0	2	2	2	2
11	SHROUD		2H9947M01	1	1	1	1
12	TRUSS HEAD TAPPING SCREW T2		FT20408F0	6	6	6	6
13	FAN MOTOR		P02545-01	1	1	1	1
14	BRACKET - FM		3Y5075M01	1	1	1	1
15	HEX HEAD BOLT (SPRING WASHER AND FLAT WASHER)		FBK0408F0	5	5	5	5
17	HEX HEAD BOLT (SPRING WASHER AND FLAT WASHER)		FBK0508F0	4	4	4	4
18	EVAPORATOR	(240ANE)	2H7526G02	1	1	1	1
		(240ANE-23)	2H1833G03	1	1	1	1
		(240ANE-21)	208205G04	1	1	1	1
19	COLLAR		3H3879-01	4	4	4	4
20	SCREW EVAPORATOR	(240ANE)	4Y4922M02	4	4	4	4
		(240ANE-21)	4Y4922M03	4	4	4	4
		(240ANE-23)					
21	WASHER		4H0777-01	4	4	4	4
22	FLANGE NUT		FNHF06S0	4	4	4	4
23	TEE		430608-02	1	1	1	1
24	EXPANSION VALVE		P01874-01	1	1	1	1
25	COPPER TUBE (A) - LOW SIDE		3Y5353G01	1	1	1	1
26	COPPER TUBE (E) - HIGH SIDE		3Y5354G01	1	1	1	1
27	COPPER TUBE (D) - HOT GAS		3Y5355G01	1	1	1	1
28	TEE		420041-11	1	1	1	1

MODEL: IM-240ANE,-21,-23			TITLE: B.REFRIGERATION ASSY				
INDEX NO.	DESCRIPTION	MATERIAL OR MODEL NUMBER	PART NUMBER	REQ'D NUMBER			
				A-1 B-0	B-1 B-2	B-3 C-0	C-1,D-0 E-0,F-0
29	PIPE(A) - HIGH SIDE		4Y6894M01	1	-	-	-
			4Y7816M01	-	1	1	1
30	TEE		420041-02	1	1	1	1
31	HEAT EXCHANGER		2X0222G01	1	-	-	-
			2X1194G01	-	1	1	1
32	PIPE(F) - HIGH SIDE		4Y6750M01	1	1	1	1
33	DRIER		458776-01	1	1	1	1
34	PROCESS TUBE		4Y0273-01	1	1	1	1
35	HOT GAS VALVE		P01871-01	1	1	1	1
36	STRAINER		P00812-01	1	1	1	1
37	PIPE(A) - HOT GAS		4Y6895M01	1	1	1	1
38	PIPE(B) - HOT GAS		4Y7012G01	1	1	1	1
39	COPPER TUBE(G) - PROCESS		3Y5356G01	1	-	-	-
			3Y6718G01	-	1	1	1
40	VALVE COVER		3Y3051P01	1	1	1	1
41	CLAMP		P00752-01	2	2	2	2
42	TIE		457167-01	1	1	1	1
43	WIRE SADDLE		428060-02	2	2	2	2
44	HOLDER - THERMISTOR		3H9642-01	1	1	1	1
45	TRUSS HEAD TAPPING SCREW (S-TITE)		FTS0408M0	1	1	1	1
46	CLIP		452254-02	2	2	2	2
47	INSULATION		4X8643-01	1	1	1	1
48	TIE		7920-0003	6	7	7	7
49	THERMISTOR(G) - FILTER		4Y4859G01	1	1	1	1
50	ALMINUM TAPE		1H4741-01	1	-	-	-
			1H5195Z01	-	1	1	1
51	CLIP - THERMISTOR		4R2938-01	1	1	1	1
52	INSULATION TUBE		H72636A80	1	1	1	1
53	INSULATION TUBE		H71323070	1	1	1	1
54	INSULATION - CONT		4Y7013P01	1	1	1	1
73	COPPER TUBE(D)-LOW SIDE		4Y7817M01	-	1	1	1
74	INSULATION TUBE		H72030390	-	1	1	1
77	WASHER	(240ANE-21)	4H1365-06	4	4	4	4
		(240ANE-23)	4H1365-05	4	4	4	4

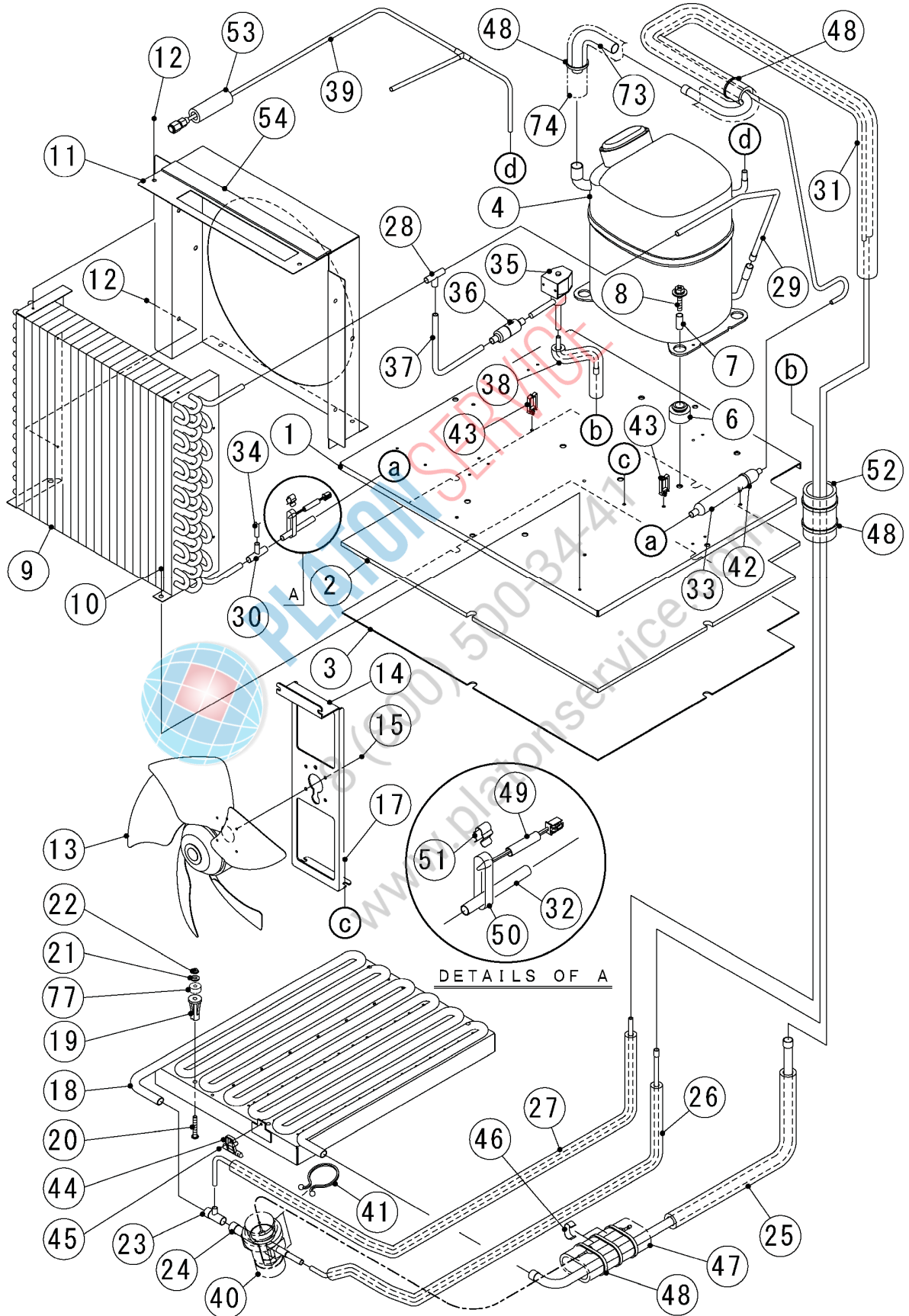

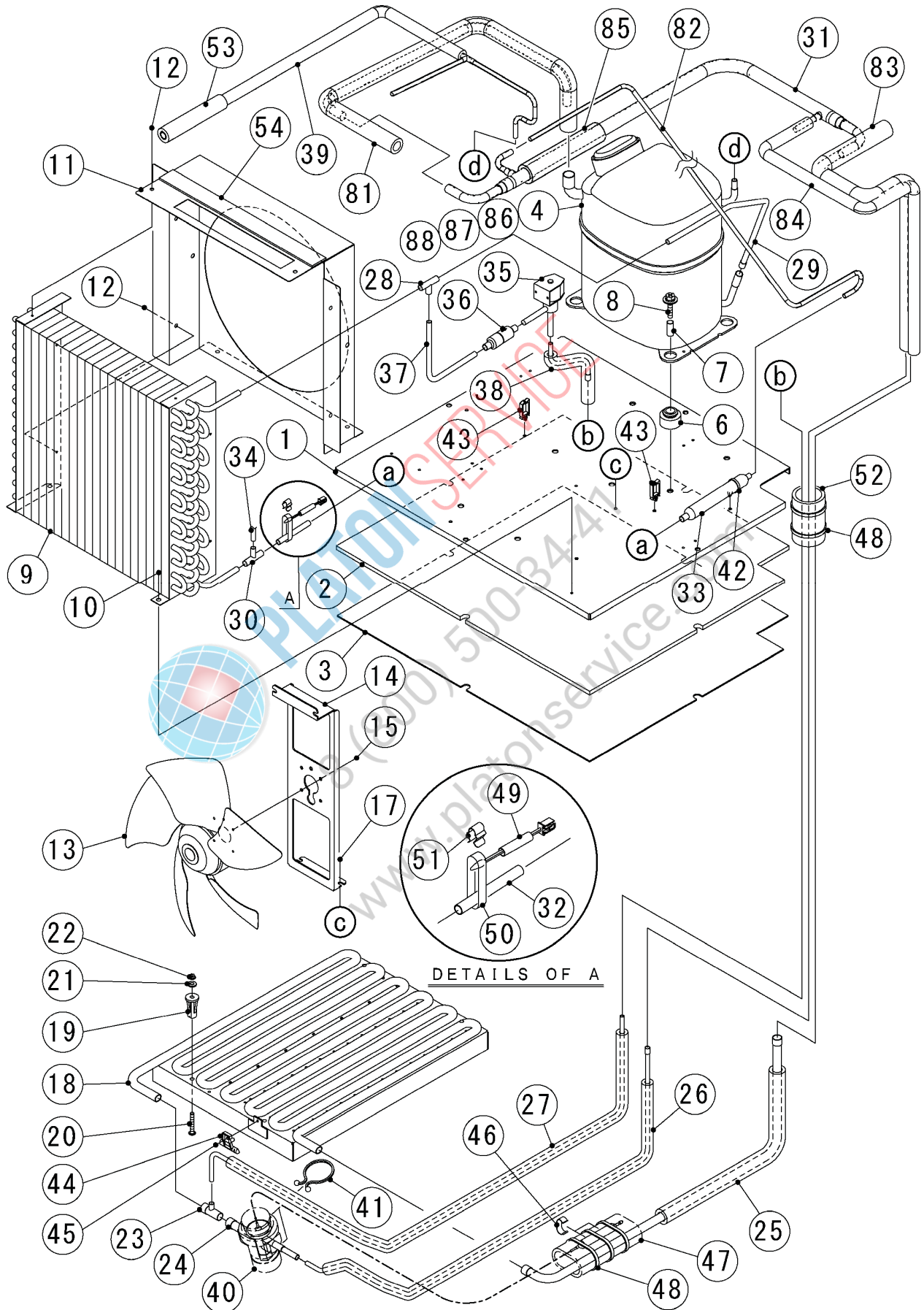

MODEL: IM-240ANE			TITLE: B.REFRIGERATION ASSY				
INDEX NO.	DESCRIPTION	MATERIAL OR MODEL NUMBER	PART NUMBER	REQ'D NUMBER			
				C-1,D-0 E-0,F-0			
1	BASE		3Y5351G01	1			
2	INSULATION - BASE		4Y6898P01	1			
3	PLATE - BASE		4Y0249-01	1			
4	COMPRESSOR		P02886-01	1			
6	RUBBER GROMMET		P01858-01	4			
7	SLEEVE		P01859-01	4			
8	BOLT		436206-03	4			
9	CONDENSER		P03307-01	1			
10	FLANGE BOLT (S-TITE)		FTR0408M0	2			
11	SHROUD		2H9947M01	1			
12	TRUSS HEAD TAPPING SCREW T2		FT20408F0	6			
13	FAN MOTOR		P02545-01	1			
14	BRACKET - FM		3Y5075M01	1			
15	HEX HEAD BOLT (SPRING WASHER AND FLAT WASHER)		FBK0408F0	5			
17	HEX HEAD BOLT (SPRING WASHER AND FLAT WASHER)		FBK0508F0	4			
18	EVAPORATOR		2H7526G02	1			
19	COLLAR		3H3879-01	4			
20	SCREW EVAPORATOR		4Y4922M02	4			
21	WASHER		4H0777-01	4			
22	FLANGE NUT		FNHF06S0	4			
23	TEE		430608-02	1			
24	EXPANSION VALVE		P01874-01	1			
25	COPPER TUBE (A) - LOW SIDE		3Y5353G01	1			
26	COPPER TUBE (E) - HIGH SIDE		3Y5354G01	1			
27	COPPER TUBE (D) - HOT GAS		3Y5355G01	1			
28	TEE		420041-11	1			
29	PIPE(A) - HIGH SIDE		4Y7816M01	1			
30	TEE		420041-02	1			
31	HEAT EXCHANGER		3Y3207G01	1			
32	PIPE(F) - HIGH SIDE		4Y6750M01	1			
33	DRIER		458776-01	1			
34	PROCESS TUBE		4Y0273-01	1			
35	HOT GAS VALVE		P01871-01	1			
36	STRAINER		P00812-01	1			

MODEL: IM-240ANE			TITLE: B.REFRIGERATION ASSY				
INDEX NO.	DESCRIPTION	MATERIAL OR MODEL NUMBER	PART NUMBER	REQ'D NUMBER			
				C-1,D-0 E-0,F-0			
37	PIPE(A) - HOT GAS		4Y6895M01	1			
38	PIPE(B) - HOT GAS		4Y7012G01	1			
39	COPPER TUBE(G) - PROCESS		3Y7372G01	1			
40	VALVE COVER		3Y3051P01	1			
41	CLAMP		P00752-01	2			
42	TIE		457167-01	1			
43	WIRE SADDLE		428060-02	2			
44	HOLDER - THERMISTOR		3H9642-01	1			
45	TRUSS HEAD TAPPING SCREW		FTS0408M0	1			
46	CLIP		452254-02	2			
47	INSULATION		4X8643-01	1			
48	TIE		7920-0003	7			
49	THERMISTOR(G) - FILTER		4Y4859G01	1			
50	ALUMINUM TAPE		1H5195Z01	1			
51	CLIP - THERMISTOR		4R2938-01	1			
52	INSULATION TUBE		H72636A80	1			
53	INSULATION TUBE		H71323120	1			
54	INSULATION - CONT		4Y7013P01	1			
81	COPPER TUBE(C)-LOW SIDE		3Y7374G01	1			
82	COPPER TUBE(B)-HIGH SIDE		3Y7377M01	1			
83	COPPER TUBE(B)-HIGH SIDE		4Y8152G01	1			
84	COPPER TUBE(C)-HIGH SIDE		4Y8153G01	1			
85	INSULATION TUBE		H72030B15	1			
86	COVER		P02888-01	1			
87	CLAMP		P01862-01	1			
88	GASKET		P01863-01	1			

B. REFRIGERATION ASSY

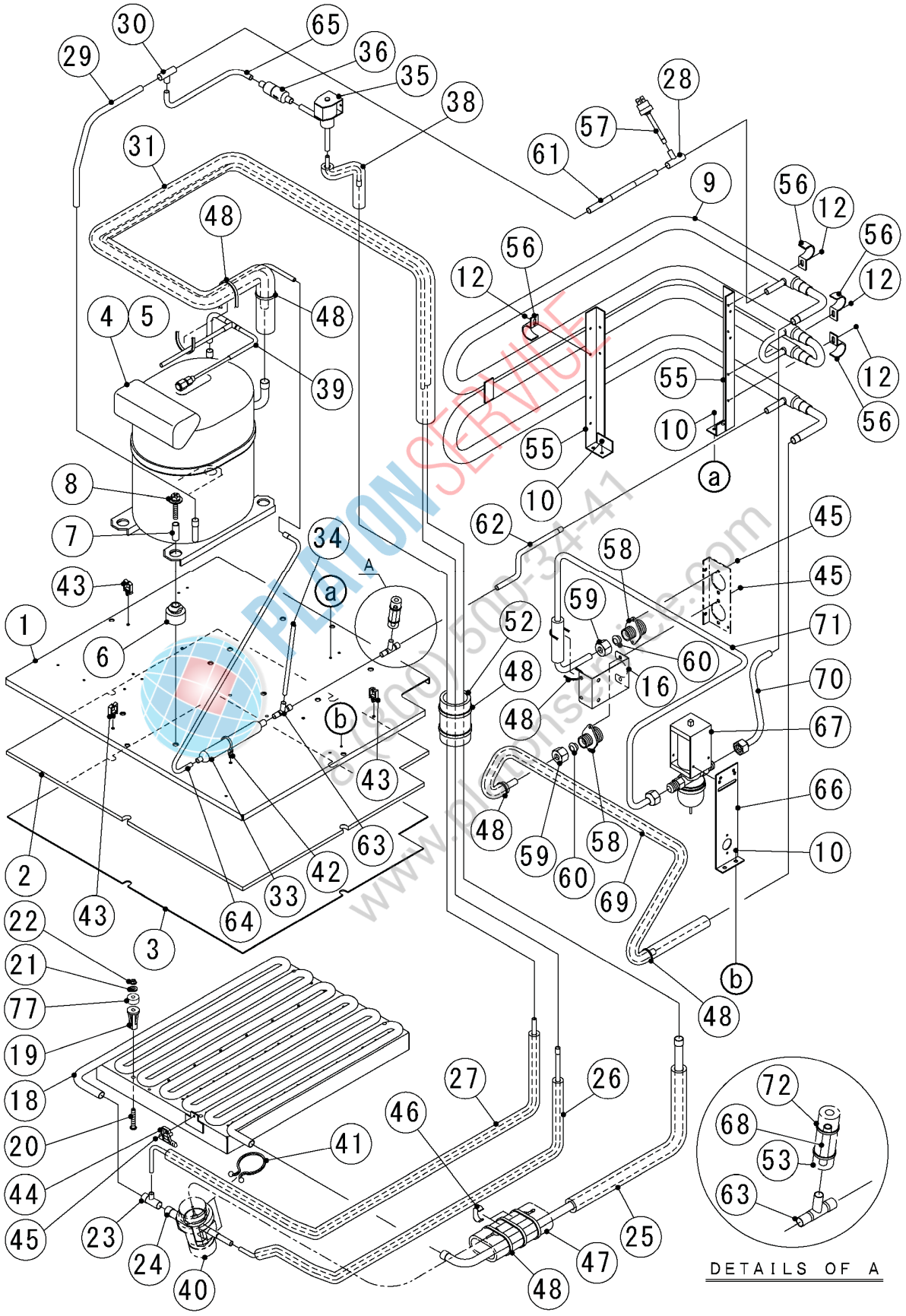

B. REFRIGERATION ASSY

50Hz (B-1) and later
60Hz (C-1) and later

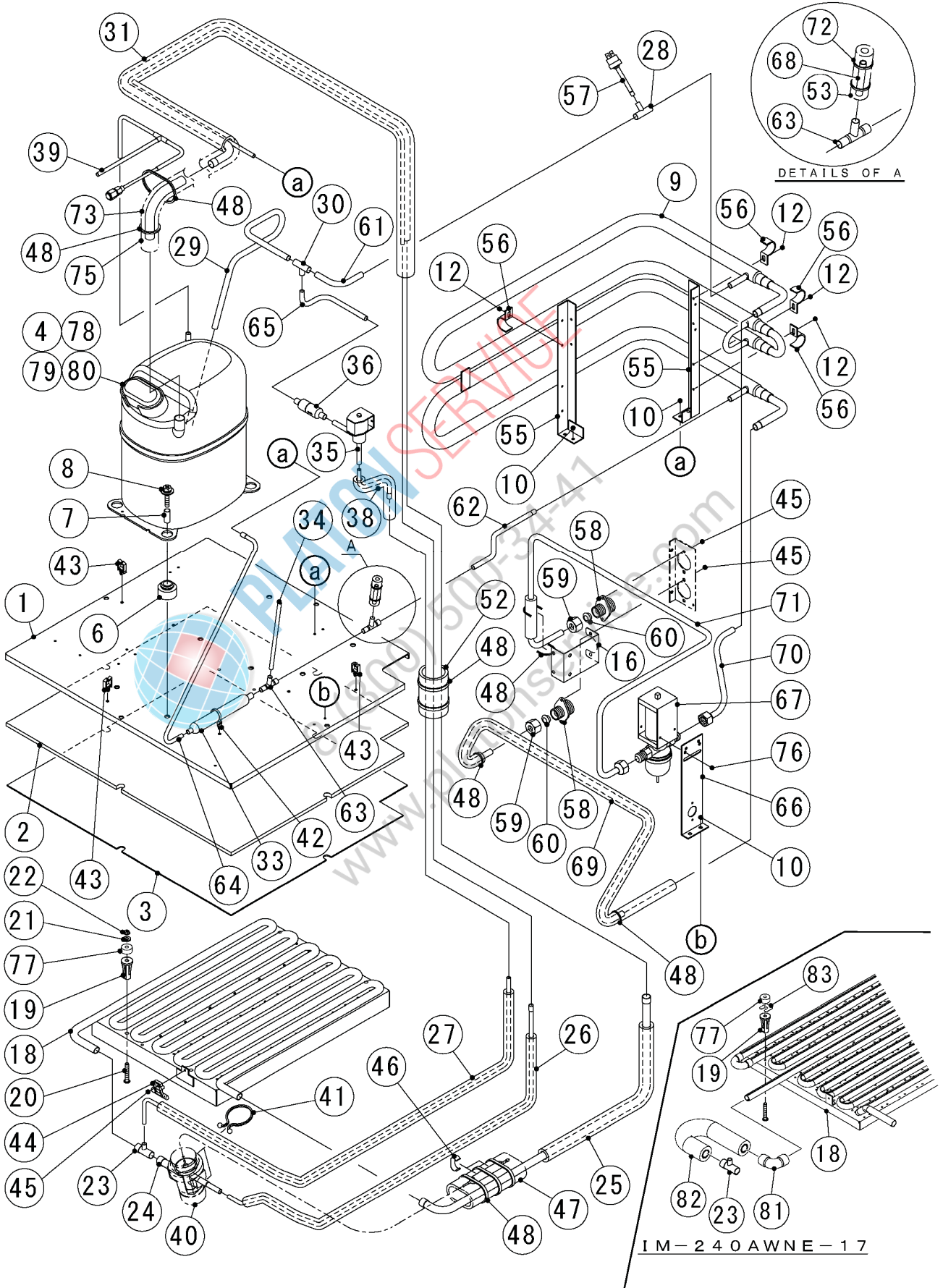

MODEL: IM-240AWNE,-23		TITLE: B.REFRIGERATION ASSY					
INDEX NO.	DESCRIPTION	MATERIAL OR MODEL NUMBER	PART NUMBER	REQ'D NUMBER			
				A-1 B-0	B-1 B-2	B-3 C-0	C-1,D-0 E-0,F-0
1	BASE		3Y5530G01	1	1	1	1
2	INSULATION - BASE		4Y6898P01	1	1	1	1
3	PLATE - BASE		4Y0249-01	1	1	1	1
4	COMPRESSOR		4A1581-01	1	-	-	-
			P01855-01	-	1	1	1
5	MOTOR PROTECTOR		4A1581F01	1	-	-	-
6	GROMMET		434922-02	4	-	-	-
	RUBBER GROMMET		P01858-01	-	4	4	4
7	SPACER		434921-01	4	-	-	-
	SLEEVE		P01859-01	-	4	4	4
8	BOLT		436206-04	4	-	-	-
			436206-03	-	4	4	4
9	CONDENSER - WATER COOLED		103099G01	1	1	1	1
10	FLANGE BOLT (S-TITE)		FTR0408M0	6	6	6	6
12	TRUSS HEAD TAPPING SCREW T2		FT20408F0	4	4	4	4
16	BRACKET - WATER PIPE		4Y7086M01	1	1	1	1
18	EVAPORATOR	(240AWNE)	2H7526G02	1	1	1	1
		(240AWNE-23)	2H1833G03	1	1	1	1
19	COLLAR		3H3879-01	4	4	4	4
20	SCREW EVAPORATOR	(240AWNE)	4Y4922M02	4	4	4	4
		(240AWNE-23)	4Y4922M03	4	4	4	4
21	WASHER		4H0777-01	4	4	4	4
22	FLANGE NUT		FNHF06S0	4	4	4	4
23	TEE		430608-02	1	1	1	1
24	EXPANSION VALVE		P01874-01	1	1	1	1
25	COPPER TUBE (A) - LOW SIDE		3Y5353G01	1	1	1	1
26	COPPER TUBE (E) - HIGH SIDE		3Y5354G01	1	1	1	1
27	COPPER TUBE (D) - HOT GAS		3Y5355G01	1	1	1	1
28	TEE		420041-05	1	1	1	1
29	PIPE(A-1) - HIGH SIDE		3Y5531M01	1	-	-	-
			4Y7836M01	-	1	1	1
30	TEE		420041-09	1	1	1	1
31	HEAT EXCHANGER		2X0352G01	1	-	-	-
			2X1238G01	-	1	1	1
33	DRIER		458776-01	1	1	1	1
34	PROCESS TUBE		4Y0273-01	1	1	1	1

MODEL: IM-240AWNE,-23		TITLE: B.REFRIGERATION ASSY					
INDEX NO.	DESCRIPTION	MATERIAL OR MODEL NUMBER	PART NUMBER	REQ'D NUMBER			
				A-1 B-0	B-1 B-2	B-3 C-0	C-1,D-0 E-0,F-0
35	HOT GAS VALVE		P01871-01	1	1	1	1
36	STRAINER		P00812-01	1	1	1	1
38	PIPE(B) - HOT GAS		4Y7012G01	1	1	1	1
39	COPPER TUBE(G) - PROCESS		3Y5534G01	1	-	-	-
			3Y6759G01	-	1	1	1
40	VALVE COVER		3Y3051P01	1	1	1	1
41	CLAMP		P00752-01	2	2	2	2
42	TIE		457167-01	1	1	1	1
43	WIRE SADDLE		428060-03	3	3	3	3
44	HOLDER - THERMISTOR		3H9642-01	1	1	1	1
45	TRUSS HEAD TAPPING SCREW (S-TITE)		FTS0408M0	5	5	5	5
46	CLIP		452254-02	2	2	2	2
47	INSULATION		4X8643-01	1	1	1	1
48	TIE		7920-0003	10	10	10	10
52	INSULATION TUBE		H72636A80	1	1	1	1
53	INSULATION - CAP		4H9594-01	1	1	1	1
55	BRACKET CONDENSER		425490-01	2	2	2	2
56	CLAMP(B) - CONDENSER		4H0622-01	4	4	4	4
57	PRESSURE SWITCH		459863-03	1	1	1	1
58	FITTING(P)		3Y0747-01	2	2	2	2
59	NUT (A) - FITTING		415713-03	2	2	2	2
60	TAPPERED PACKING		415715-01	2	2	2	2
61	COPPER TUBE(A-2) - HIGH SIDE		4Y7079M01	1	-	-	-
			4Y7834M01	-	1	1	1
62	COPPER TUBE(B) - HIGH SIDE		4Y7080M01	1	1	1	1
63	TEE		4Y4060Z01	2	2	2	2
64	COPPER TUBE(C) - HIGH SIDE		4Y7081M01	1	-	-	-
			4Y7838M01	-	1	1	1
65	COPPER TUBE(A) - HOT GAS		4Y7082M01	1	-	-	-
			4Y7835M01	-	1	1	1
66	BRACKET - WATER REGURATOR		4X5632-01	1	1	1	1
67	WATER REGULATOR		P04025-01	1	1	1	1
68	TUBE - CAPILLARY		4X4276-01	1	1	1	1
69	COPPER TUBE(A) - WATER		3Y5532G01	1	1	1	1
70	COPPER TUBE(B) - WATER		4Y7083G01	1	1	1	1

HE,GENERAL

【50Hz】

MODEL: IM-240AWNE,-23		TITLE: B.REFRIGERATION ASSY					
INDEX NO.	DESCRIPTION	MATERIAL OR MODEL NUMBER	PART NUMBER	REQ'D NUMBER			
				A-1 B-0	B-1 B-2	B-3 C-0	C-1,D-0 E-0,F-0
71	COPPER TUBE(C) - WATER		3Y5533G01	1	1	1	1
72	NYLON TIE		7920-0002	2	2	2	2
73	COPPER TUBE(D)-LOW SIDE	(EXCEPT 240AWNE,-21,-23 60Hz)	4Y7817M01	-	1	1	1
75	INSULATION TUBE		H72030300	-	1	1	1
76	TRUSS HEAD SCREW		FST0408S0	-	2	2	2
77	WASHER	(240AWNE-23)	4H1365-05	4	4	4	4



PLATON SERVICE

8 (800) 500-34-41

www.platonservice.com

MODEL: IM-240AWNE,-21,-23,-17		TITLE: B.REFRIGERATION ASSY					
INDEX NO.	DESCRIPTION	MATERIAL OR MODEL NUMBER	PART NUMBER	REQ'D NUMBER			
				A-1 B-0	B-1 B-2	B-3 C-0	C-1,D-0 E-0,F-0
1	BASE		3Y5530G01	1	1	1	1
2	INSULATION - BASE		4Y6898P01	1	1	1	1
3	PLATE - BASE		4Y0249-01	1	1	1	1
4	COMPRESSOR		4A1322-01	1	1	1	-
			P02886-01	-	-	-	1
5	-		-	-	-	-	-
6	GROMMET		434922-02	4	4	4	-
	RUBBER GROMMET		P01858-01	-	-	-	4
7	SPACER		434921-01	4	4	4	-
	SLEEVE		P01859-01	-	-	-	4
8	BOLT		436206-04	4	4	4	-
			436206-03	-	-	-	4
9	CONDENSER - WATER COOLED		103099G01	1	1	1	1
10	FLANGE BOLT (S-TITE)		FTR0408M0	6	6	6	6
12	TRUSS HEAD TAPPING SCREW T2		FT20408F0	4	4	4	4
16	BRACKET - WATER PIPE		4Y7086M01	1	1	1	1
18	EVAPORATOR	(240AWNE)	2H7526G02	1	1	1	1
		(240AWNE-23)	2H1833G03	1	1	1	1
		(240AWNE-21)	208205G04	1	1	1	1
		(240AWNE-17)	2X1849G01	-	-	-	1
19	COLLAR		3H3879-01	4	4	4	4
20	SCREW EVAPORATOR	(240AWNE)	4Y4922M02	4	4	4	4
		(240AWNE-21) (240AWNE-23) (240AWNE-17)	4Y4922M03	4	4	4	4
21	WASHER		4H0777-01	4	4	4	4
22	FLANGE NUT		FNHF06S0	4	4	4	4
23	TEE		430608-02	1	1	1	1
24	EXPANSION VALVE		P01874-01	1	1	1	1
25	COPPER TUBE (A) - LOW SIDE		3Y5353G01	1	1	1	1
26	COPPER TUBE (E) - HIGH SIDE		3Y5354G01	1	1	1	1
27	COPPER TUBE (D) - HOT GAS		3Y5355G01	1	1	1	1
28	TEE		420041-05	1	1	1	1
29	PIPE(A-1) - HIGH SIDE		3Y5531M01	1	1	1	-
			4Y7836M01	-	-	-	1
30	TEE		420041-09	1	1	1	1
31	HEAT EXCHANGER		2X1554G01	1	1	1	1

MODEL: IM-240AWNE,-21,-23,-17		TITLE: B.REFRIGERATION ASSY					
INDEX NO.	DESCRIPTION	MATERIAL OR MODEL NUMBER	PART NUMBER	REQ'D NUMBER			
				A-1 B-0	B-1 B-2	B-3 C-0	C-1,D-0 E-0,F-0
33	DRIER		458776-01	1	1	1	1
34	PROCESS TUBE		4Y0273-01	1	1	1	1
35	HOT GAS VALVE		P01871-01	1	1	1	1
36	STRAINER		P00812-01	1	1	1	1
38	PIPE(B) - HOT GAS		4Y7012G01	1	1	1	1
39	COPPER TUBE(G) - PROCESS		3Y5534G01	-	1	1	-
			3Y6759G01	-	-	-	1
40	VALVE COVER		3Y3051P01	1	1	1	1
41	CLAMP		P00752-01	2	2	2	2
42	TIE		457167-01	1	1	1	1
43	WIRE SADDLE		428060-03	3	3	3	3
44	HOLDER - THERMISTOR		3H9642-01	1	1	1	1
45	TRUSS HEAD TAPPING SCREW (S-TITE)		FTS0408M0	5	5	5	5
46	CLIP		452254-02	2	2	2	2
47	INSULATION		4X8643-01	1	1	1	1
48	TIE		7920-0003	10	10	10	10
52	INSULATION TUBE		H72636A80	1	1	1	-
			H72030300	-	-	-	1
53	INSULATION - CAP		4H9594-01	1	1	1	1
55	BRACKET CONDENSER		425490-01	2	2	2	2
56	CLAMP(B) - CONDENSER		4H0622-01	4	4	4	4
57	PRESSURE SWITCH		459863-03	1	1	1	1
58	FITTING(P)		3Y0747-01	2	2	2	2
59	NUT (A) - FITTING		415713-03	2	2	2	2
60	TAPPERED PACKING		415715-01	2	2	2	2
61	COPPER TUBE(A-2) - HIGH SIDE		4Y7079M01	1	1	1	-
			4Y7834M01	-	-	-	1
62	COPPER TUBE(B) - HIGH SIDE		4Y7080M01	1	1	1	1
63	TEE		4Y4060Z01	2	2	2	2
64	COPPER TUBE(C) - HIGH SIDE		4Y7081M01	1	1	1	-
			4Y7838M01	-	-	-	1
65	COPPER TUBE(A) - HOT GAS		4Y7082M01	1	1	1	-
			4Y7835M01	-	-	-	1
66	BRACKET - WATER REGURATOR		4X5632-01	1	1	1	1
67	WATER REGULATOR		P04025-01	1	1	1	1

MODEL:		TITLE: B.REFRIGERATION ASSY					
IM-240AWNE,-21,-23,-17							
INDEX NO.	DESCRIPTION	MATERIAL OR MODEL NUMBER	PART NUMBER	REQ'D NUMBER			
				A-1 B-0	B-1 B-2	B-3 C-0	C-1,D-0 E-0,F-0
68	TUBE - CAPILLARY		4X4276-01	1	1	1	1
69	COPPER TUBE(A) - WATER		3Y5532G01	1	1	1	1
70	COPPER TUBE(B) - WATER		4Y7083G01	1	1	1	1
71	COPPER TUBE(C) - WATER		3Y5533G01	1	1	1	1
72	NYLON TIE		7920-0002	2	2	2	2
76	TRUSS HEAD SCREW		FST0408S0	-	2	2	2
77	WASHER	(240AWNE-21)	4H1365-06	4	4	4	4
		(240AWNE-23)	4H1365-05	4	4	4	4
		(240AWNE-17)	4H1365-11	-	-	-	4
78	COVER		P02888-01	-	-	-	1
79	CLAMP		P01862-01	-	-	-	1
80	GASKET		P01863-01	-	-	-	1
81	ELBOW	(240AWNE-17)	417395-03	-	-	-	1
82	CONNECT PIPE	(240AWNE-17)	4Y8503G01	-	-	-	1
83	SPACER	(240AWNE-17)	4Y8450M01	-	-	-	4



IM-240ANE (-21, -23)
IM-240AWNE (-21, -23, -17)

C. MECHANISM ASSY

(A-1) and later

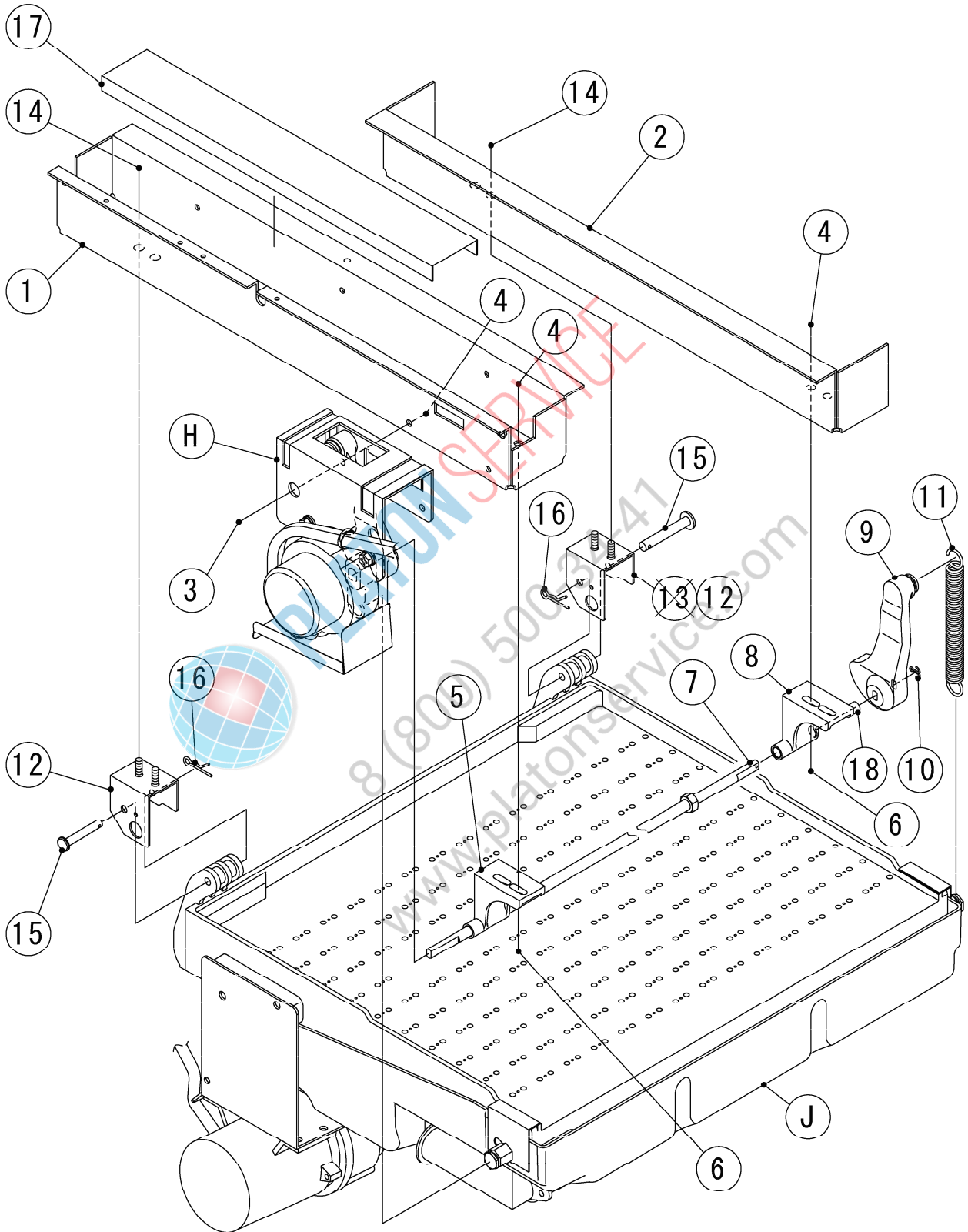

HE,GENERAL,KOREA

MODEL: IM-240ANE,-21,-23 IM-240AWNE,-21,-23,-17				TITLE: C.MECHANISM ASSY			
INDEX NO.	DESCRIPTION	MATERIAL OR MODEL NUMBER	PART NUMBER	REQ'D NUMBER			
				A-1 B-0	B-1 B-2	B-3 C-0	C-1,D-0 E-0,F-0
H	ACTUATOR MOTOR ASSY		3Y8848A01	1	1	1	1
J	WATER PAN ASSY		1H4689A01	1	1	1	1
1	FRAME - FRONT		2X0224M01	1	1	1	1
2	FRAME - REAR		2X0225M01	1	1	1	1
3	TRUSS HEAD MACHINE SCREW		FST0512S0	2	2	2	2
4	FLANGE NUT		FNHF05S0	6	6	6	6
5	BEARING - CAM SHAFT		3X8307-02	1	1	1	1
		(240ANE-21) (240AWNE-21)	3X8307-01	-	-	-	1
6	TRUSS HEAD MACHINE SCREW		FST0516S0	4	4	4	4
7	CAM SHAFT		425511G01	1	1	1	1
8	BEARING - CAM SHAFT		3X8307-02	1	1	1	1
9	CAM (B)		376546P01	1	1	1	1
10	COTTER PIN		711S-0212	1	1	1	1
11	EXTEN SPRING		4H3473-01	1	1	1	1
12	BEARING PLATE		3H1440G03	2	2	2	2
13	BEARING PLATE		3H1440G04	-	-	-	-
14	FLANGE NUT		FNHF06S0	4	4	4	4
15	SHAFT (B)		4H1184-02	2	2	2	2
16	SNAP PIN		715S-0006	2	2	2	2
17	GUIDE - CONNECTOR		4H5619-01	1	1	1	1
18	COLLAR	(240ANE-21) (240AWNE-21) (240AWNE-17)	429124-01	1	1	1	1

IM-240ANE (-21,-23)
IM-240AWNE(-21,-23,-17)

D. WATER CIRCUIT ASSY

(A-1) and later

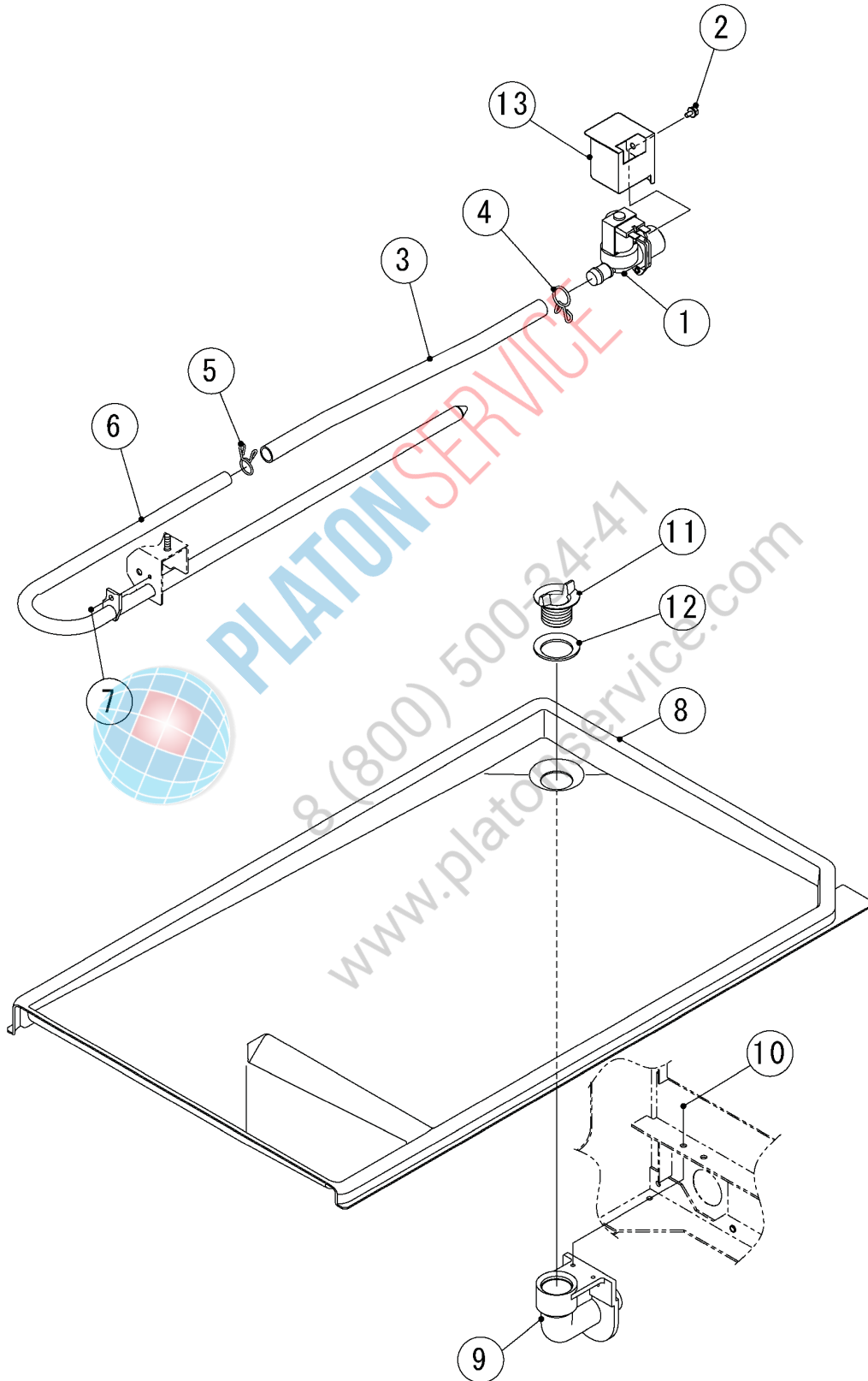

HE,GENERAL,KOREA

MODEL: IM-240ANE,-21,-23 IM-240AWNE,-21,-23,-17				TITLE: D.WATER CIRCUIT ASSY			
INDEX NO.	DESCRIPTION	MATERIAL OR MODEL NUMBER	PART NUMBER	REQ'D NUMBER			
				A-1 B-0	B-1 B-2	B-3 C-0	C-1,D-0 E-0,F-0
1	WATER VALVE		P02056-01	1	1	1	1
2	HEX HEAD BOLT (SPRING WASHER AND FLAT WASHER)		FBK0408S0	2	2	2	2
3	SILICONE HOSE		4Y6912R04	1	1	1	1
4	HOSE CLAMP		435934-03	1	1	1	1
5	HOSE CLAMP		435934-02	1	1	1	1
6	WATER SUPPLY PIPE		3H9533G01	1	1	1	1
7	TRUSS HEAD MACHINE SCREW		FST0412S0	1	1	1	1
8	DRAIN PAN(AD)		3X6460-01	1	1	1	1
9	DRAIN PIPE		315825-01	1	1	1	1
10	TRUSS HEAD TAPPING SCREW T2		FT20410M0	2	2	2	2
11	DRAIN YOKE		418296-01	1	1	1	1
12	PACKING		413857-01	1	1	1	1
13	COVER-WATER VALVE		3Y6277M01	1	1	1	1



PLATON SERVICE
 8 (800) 500-3411
 www.platonservice.com

IM-240ANE (-21, -23)
IM-240AWNE (-21, -23)

E. CONTROL BOX ASSY

50Hz (K-1) to (B-0)
60Hz (K-1) to (C-0)

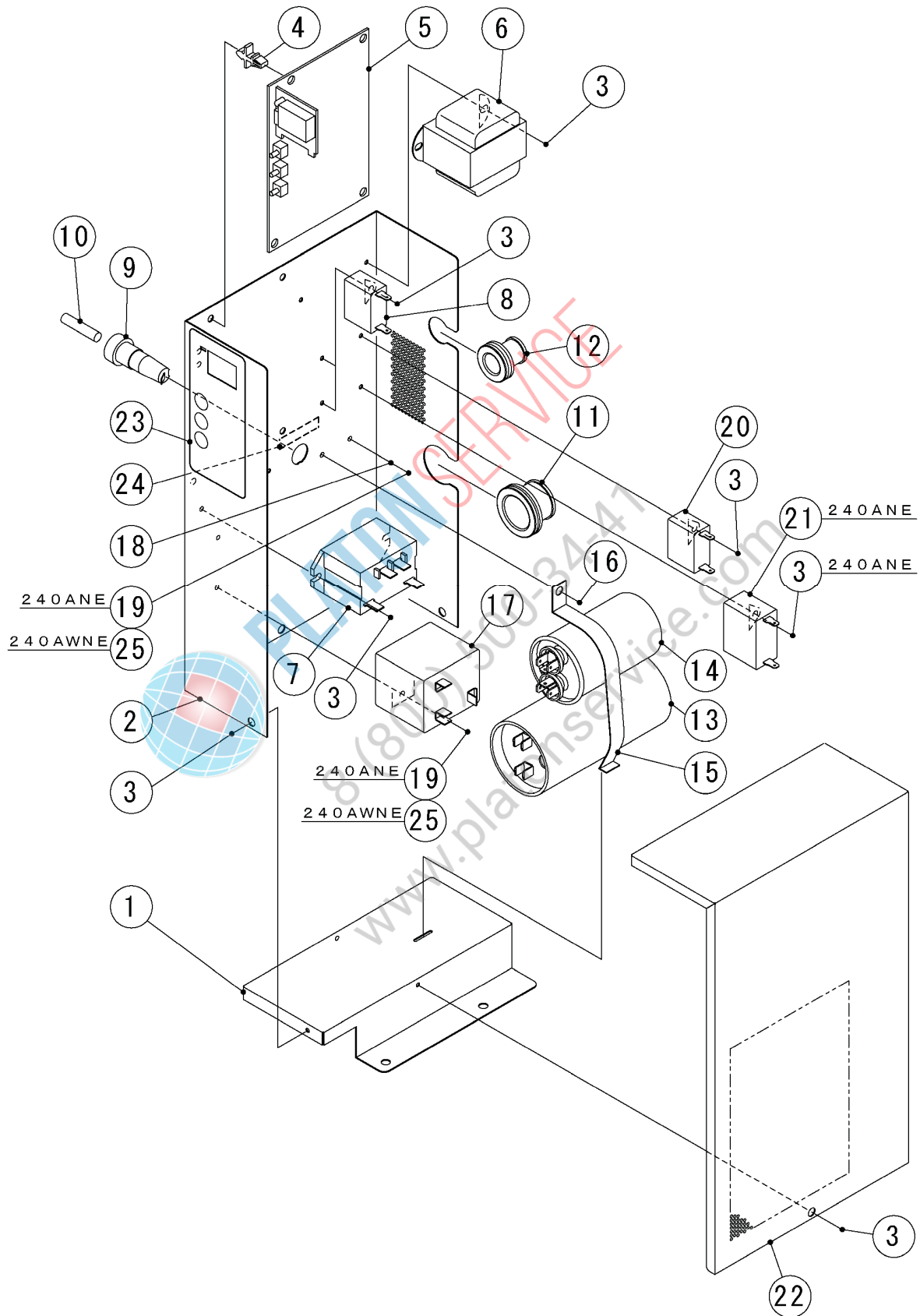

IM-240ANE (-21,-23)
IM-240AWNE(-21,-23,-17)

E. CONTROL BOX ASSY

50Hz (B-1) and later
60Hz (C-1) and later

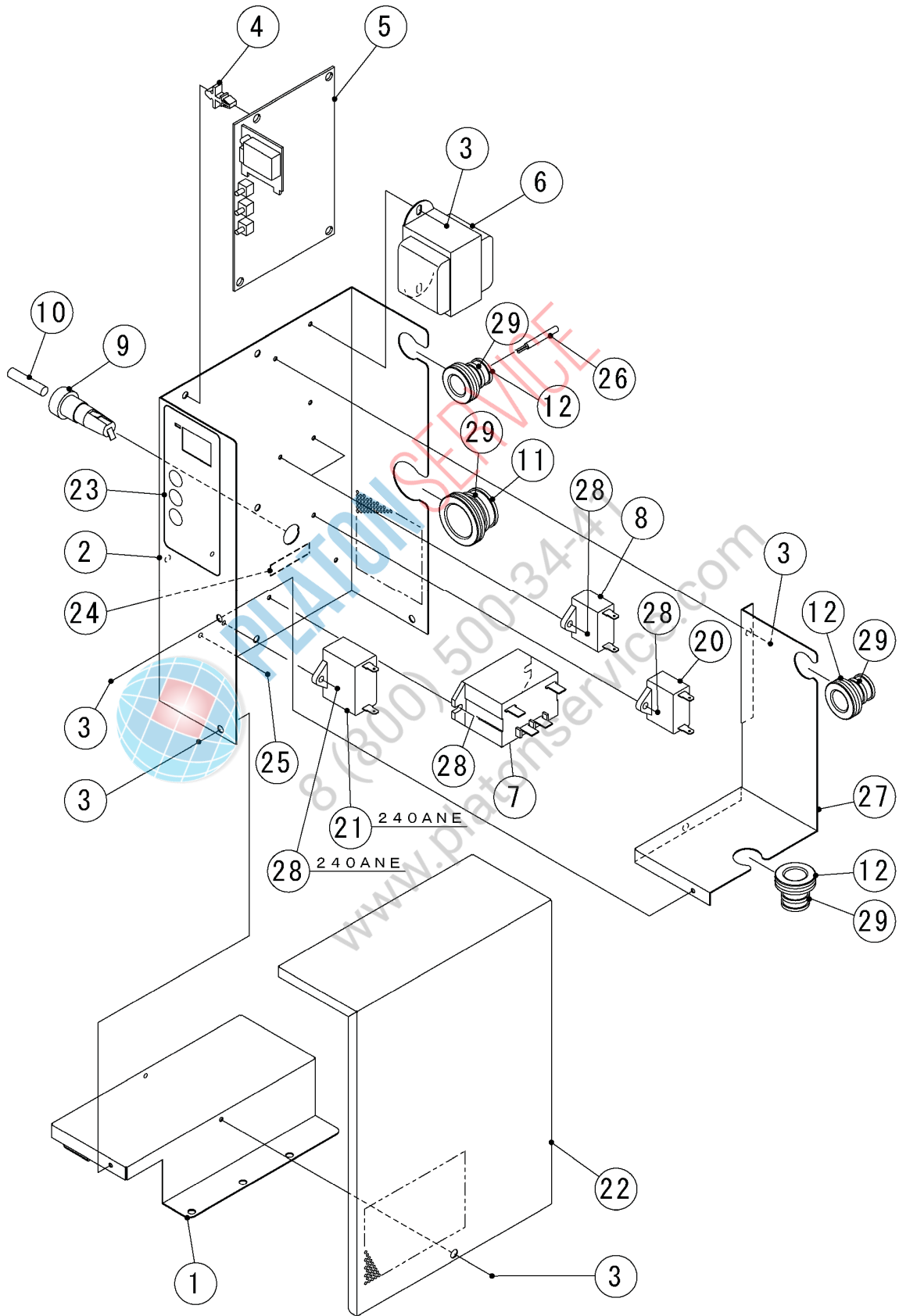

HE,GENERAL,KOREA

MODEL: IM-240ANE,-21,-23 IM-240AWNE,-21,-23,-17				TITLE: E.CONTROL BOX ASSY			
INDEX NO.	DESCRIPTION	MATERIAL OR MODEL NUMBER	PART NUMBER	REQ'D NUMBER			
				A-1 B-0	B-1 B-2	B-3 C-0	C-1,D-0 E-0,F-0
1	CONTROLBOX - BASE	(50Hz)	3Y5369M01	1	-	-	-
			3Y6722M01	-	1	1	1
		(60Hz)	3Y5369M01	1	1	1	-
			3Y6722M01	-	-	-	1
2	CONTROL BOX - BODY	(50Hz)	2X0230M01	1	-	-	-
	CONTROL BOX(B)		2X1053M01	-	1	-	-
	CONTROL BOX - BODY	(60Hz)	2X1251M01	-	-	1	1
			CONTROL BOX(B)	2X0230M01	1	1	1
3	TRUSS HEAD TAPPING SCREW T2	(240ANE,-21,-23)	FT20408F0	12	9	9	9
		(240AWNE,-23)(50Hz)		11	9	9	9
		(240AWNE,-21,-23,-17)(60Hz)		11	11	11	9
4	BOARD SUPPORT		P04204-01	4	4	4	4
5	CONTROLLER BOARD		P01873-01	1	1	1	1
6	TRANSFORMER		P02714-01	1	1	1	1
7	POWER RELAY		P00034-01	1	1	1	1
8	CAPACITOR		P01870-01	2	2	2	2
9	FUSE HOLDER	(50Hz)	P00014-01	1	1	-	-
			P02829-01	-	-	1	1
		(60Hz)	P00014-01	1	1	1	-
			P02829-01	-	-	-	1
10	FUSE	(50Hz)	P01876-01	1	1	-	-
			P04203-01	-	-	1	1
		(60Hz)	P01876-01	1	1	1	-
			P04203-01	-	-	-	1
11	GROMMET		4H2568-01	1	1	1	1
12	GROMMET	(50Hz)	4H2568-02	1	3	3	3
		(60Hz)		1	1	1	3
13	START CAPACITOR	(50Hz) 3535B7C0064A250A5	3A0076-14	1	-	-	-
	CAPACITOR - STARTING	(60Hz)	3A0076-02	1	1	-	-
14	CAPACITOR - RUN	(50Hz)	3A2005-01	1	-	-	-
		(60Hz)	3A2005-10	1	1	-	-
15	BAND	(50Hz)	427254-01	1	-	-	-
		(60Hz)	427254-13	1	1	-	-

HE, GENERAL, KOREA

MODEL: IM-240ANE,-21,-23 IM-240AWNE,-21,-23,-17		TITLE: E.CONTROL BOX ASSY					
INDEX NO.	DESCRIPTION	MATERIAL OR MODEL NUMBER	PART NUMBER	REQ'D NUMBER			
				A-1 B-0	B-1 B-2	B-3 C-0	C-1,D-0 E-0,F-0
16	FLANGE BOLT (S-TITE)	(50Hz)	FTR0408M0	1	-	-	-
		(60Hz)		1	1	-	-
17	STARTER	(50Hz)	4A1107-02	1	-	-	-
		(60Hz)	4A1107-13	1	1	-	-
18	SPRING WASHER	(50Hz)	FWSP04S0	1	-	-	-
		(60Hz)		1	1	-	-
19	TRUSS HEAD TAPPING SCREW (S-TITE)	(240ANE,-21,-23)	FTS0408M0	2	-	-	-
20	CAPACITOR		P01910-01	1	1	1	1
21	CAPACITOR	(240ANE,-21,-23)	P01865-01	1	1	1	1
22	CONTROL BOX - COVER	(50Hz)	3Y5371M01	1	-	-	-
			3Y6513M01	-	1	1	1
		(60Hz)	3Y5371M01	1	1	1	-
			3Y6513M01	-	-	-	1
23	CONTROL LABEL		475642L01	1	1	1	1
24	LABEL - FUSE		466798-01	1	1	1	1
25	TRUSS HEAD MACHINE SCREW	(240ANE,-21,-23)	FST0408S0	-	1	1	1
		(240AWNE,-23)(50Hz)	FST0408S0	2	1	1	1
		(240AWNE,-21,-23,-17)(60Hz)		2	2	2	1
26	THERMISTOR-CUBE COTROL		P00350-01	1	1	1	1
27	SEPARATOR - BOX	(50Hz)	3Y6512M01	-	1	1	1
		(60Hz)		-	-	-	1
28	TRUSS HEAD TAPPING SCREW	(240ANE,-21,-23)	FT20410F0	-	6	6	6
		(240AWNE,-21,-23,-17)		-	5	5	5
29	TIE	(50Hz)	7920-0003	-	4	4	4

IM-240ANE (-21,-23)
IM-240AWNE(-21,-23,-17)

F. BIN SWITCH-2 ASSY

(A-1) and later

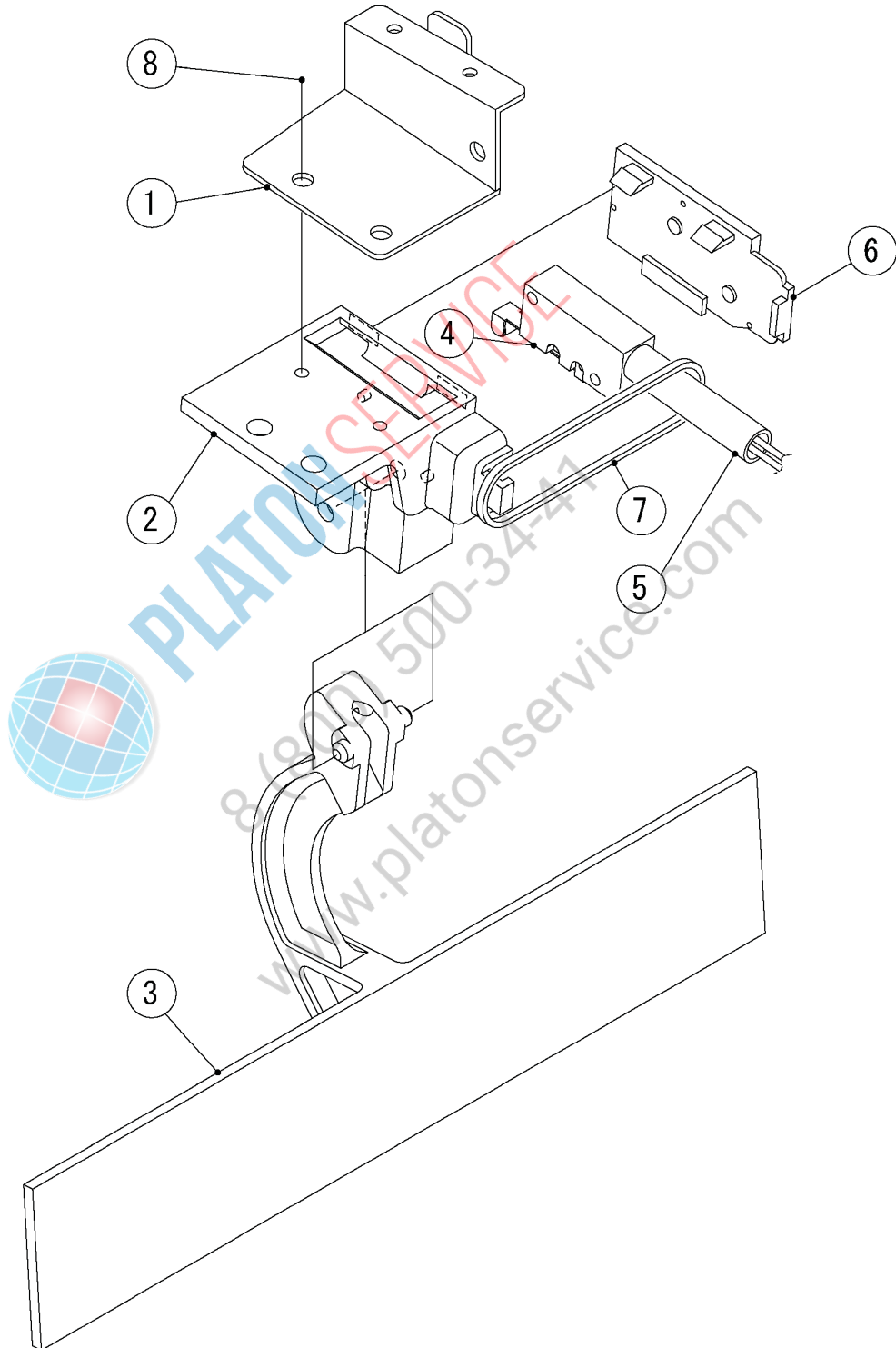

HE,GENERAL,KOREA

MODEL: IM-240ANE,-21,-23 IM-240AWNE,-21,-23,-17		TITLE: F.BIN SWITCH - 2 ASSY					
INDEX NO.	DESCRIPTION	MATERIAL OR MODEL NUMBER	PART NUMBER	REQ'D NUMBER			
				A-1 B-0	B-1 B-2	B-3 C-0	C-1,D-0 E-0,F-0
1	BRACKET - BIN SWITCH		4Y6892M01	1	1	1	1
2	SWICH BOX		2H2043-01	1	1	1	1
3	SWICH - ACTUATOR		2H7202-01	1	1	1	1
4	MICRO SWITCH		456432-01	1	1	1	1
5	TUBE - SILICONE		4X8017-03	1	1	1	1
6	SWITCH BOX COVER		4H8785-01	1	1	1	1
7	NYLON TIE	CV-100	7920-0002	1	1	1	1
8	TRUSS HEAD TAPPING SCREW T2		FT20410M0	2	2	2	2



PLATON SERVICE
 8 (800) 500-34-41
www.platonservice.com

IM-240ANE (-21,-23)
IM-240AWNE(-21,-23,-17)

G. FRONT COVER ASSY

(A-1) and later

IM-240ANE

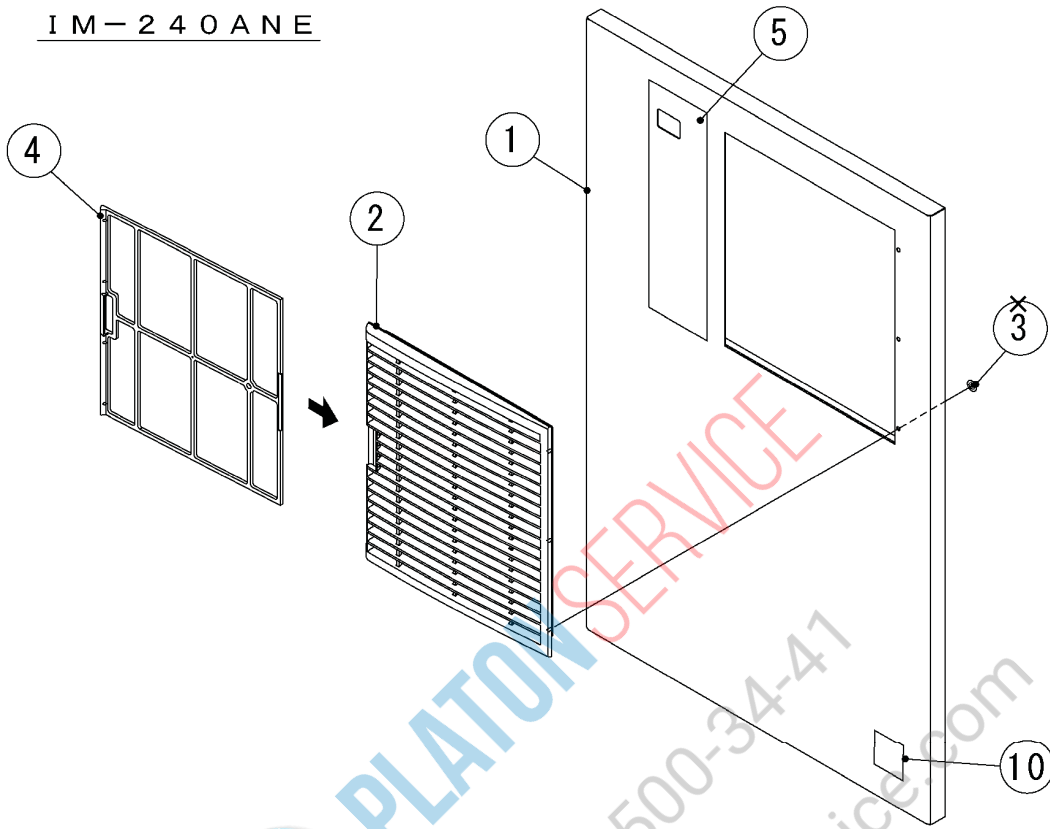

IM-240AWNE

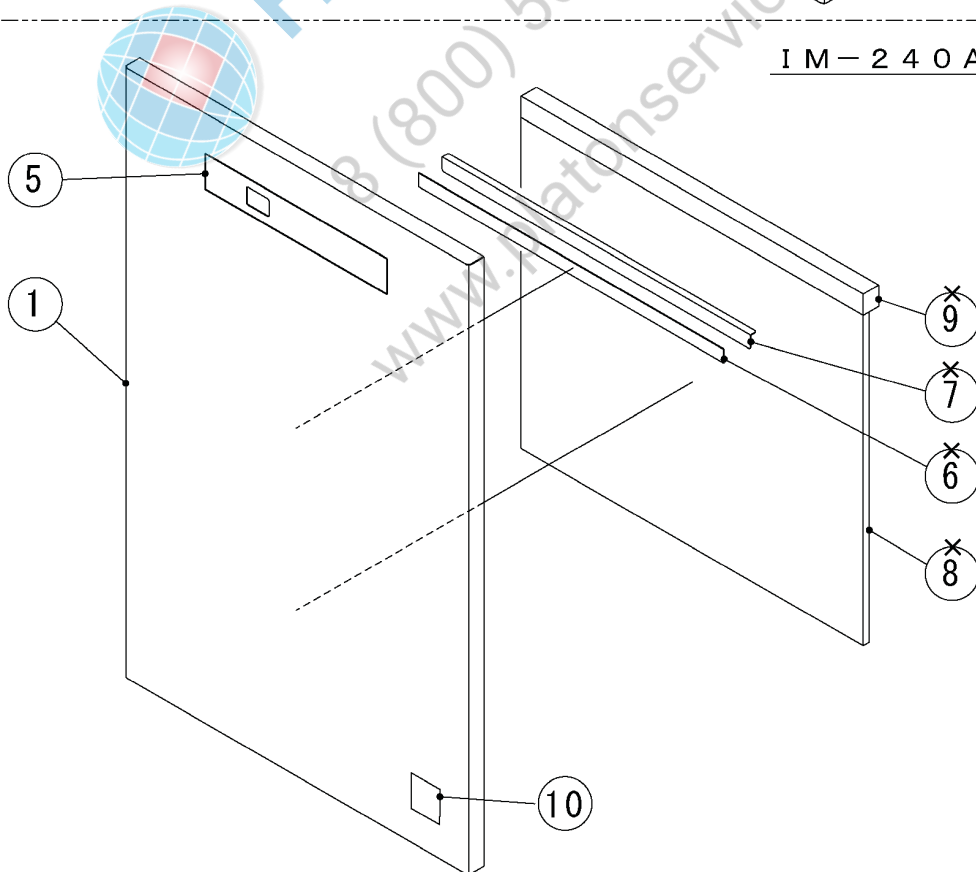

HE, GENERAL, KOREA

MODEL: IM-240ANE,-21,-23 IM-240AWNE,-21,-23,-17		TITLE: G.FRONT COVER ASSY					
INDEX NO.	DESCRIPTION	MATERIAL OR MODEL NUMBER	PART NUMBER	REQ'D NUMBER			
				A-1 B-0	B-1 B-2	B-3 C-0	C-1,D-0 E-0,F-0
1	FRONT COVER	(240ANE,-21,-23)	2X0239G01	1	-	-	-
			2X1199G01	-	1	1	1
	FRONT COVER G	(240AWNE,-23) (50Hz)	2X1143G01	1	-	-	-
			2X1240G01	-	1	1	1
	FRONT COVER	(240AWNE,-21,-23) (60Hz)	2X1143G01	1	1	1	-
2	LOUVER A	(240ANE,-21,-23)	1A0547-01	1	-	-	-
	LOUVER		121931P01	-	1	1	1
3	PUSH RETAINER	(240ANE)(60Hz)	4A2414-01	3	3	-	-
4	AIR FILTER A	(240ANE,-21,-23)	2A2062G01	1	-	-	-
	AIR FILTER		262259G01	-	1	1	1
5	OPERATION LABEL	(240ANE,-21,-23)	374961L01	1	-	-	-
			374961L02	-	1	1	1
		(240AWNE,-21,-23,-17)	374135L01	1	-	-	-
			374135L02	-	1	1	1
6	TAPE - FRONT	(240AWNE)	4Y6922Z01	1	-	-	-
7	PLATE - FRONT	(240AWNE)	4Y6921M01	1	-	-	-
8	INSULATION - FRONT (A)	(240AWNE)	4Y6923P01	1	-	-	-
9	INSULATION - SEPARATOR	(240AWNE)	4Y6924P01	1	-	-	-
10	LABEL - HACCP		476519L01	1	1	1	1

IM-240ANE (-21, -23)
IM-240AWNE (-21, -23, -17)

H. ACTUATOR MOTOR ASSY (A-1) and later

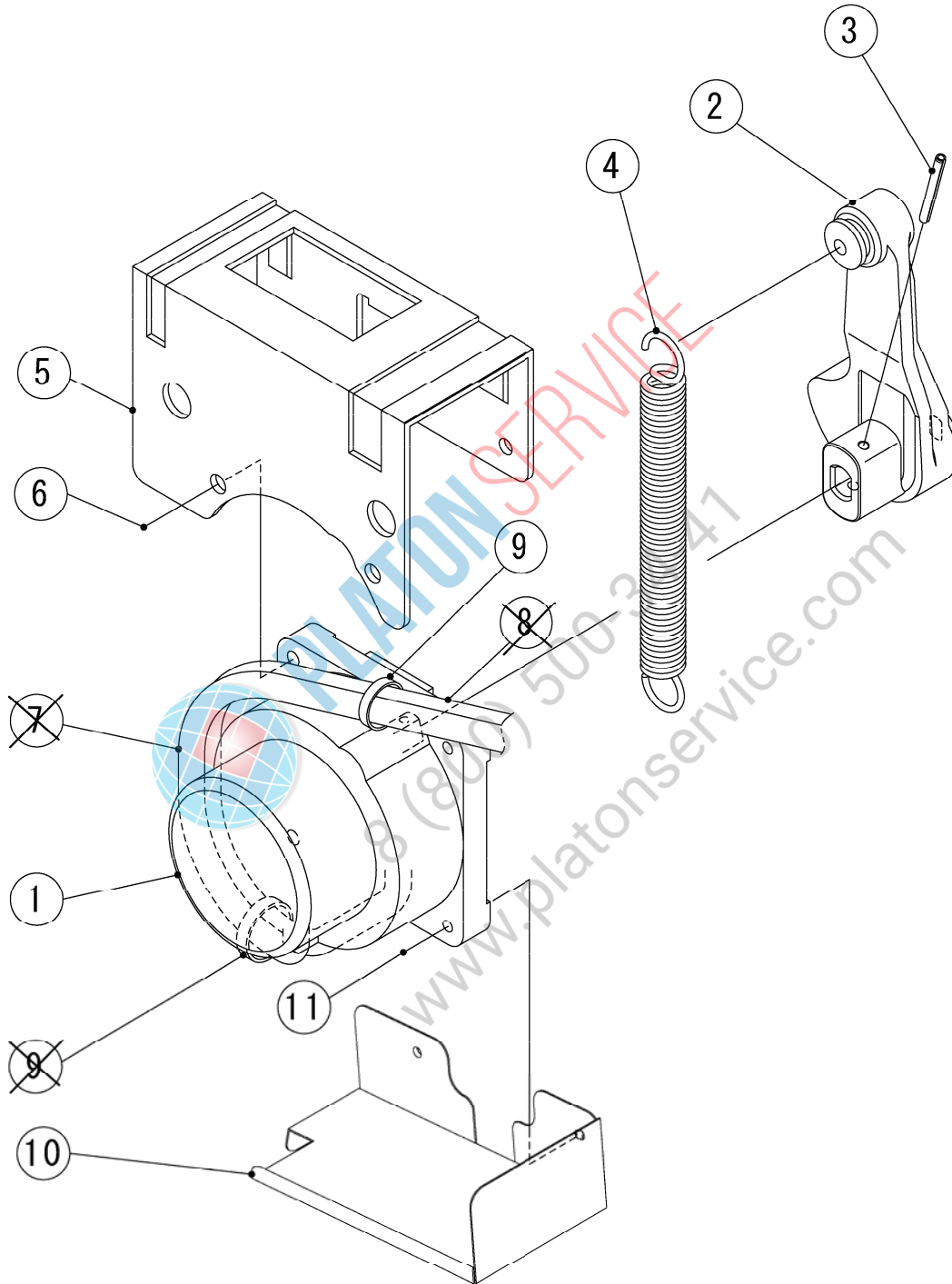

HE,GENERAL,KOREA

MODEL: IM-240ANE,-21,-23 IM-240AWNE,-21,-23,-17				TITLE: H.ACTUATOR MOTOR ASSY			
INDEX NO.	DESCRIPTION	MATERIAL OR MODEL NUMBER	PART NUMBER	REQ'D NUMBER			
				A-1 B-0	B-1 B-2	B-3 C-0	C-1,D-0 E-0,F-0
1	ACTUATOR MOTOR		4Y8998G01	1	1	1	1
2	CAM(A)		306543G03	1	1	1	1
3	SPRING PIN	3*28	712S-0328	1	1	1	1
4	EXTEN SPRING		4H3473-01	1	1	1	1
5	BRACKET - AM		3Y2924M01	1	1	1	1
6	HEX HEAD BOLT (SPRING WASHER AND FLAT WASHER)		FBK0620S0	2	2	2	2
7	TUBE-SILICONE		4Y6751Z02	-	-	-	-
8	TUBE-SILICONE		4X8017-07	-	-	-	-
9	TIE	CV-150	7920-0003	1	1	1	1
10	COVER - AM		3Y7525M01	1	1	1	1
11	HEX HEAD BOLT (SPRING WASHER AND FLAT WASHER)		FBK0416S0	2	2	2	2



PLATON SERVICE
 8 (800) 500-3444
 www.platonservice.com

IM-240ANE (-21,-23)
IM-240AWNE(-21,-23,-17)

J. WATER PAN ASSY

(A-1) and later

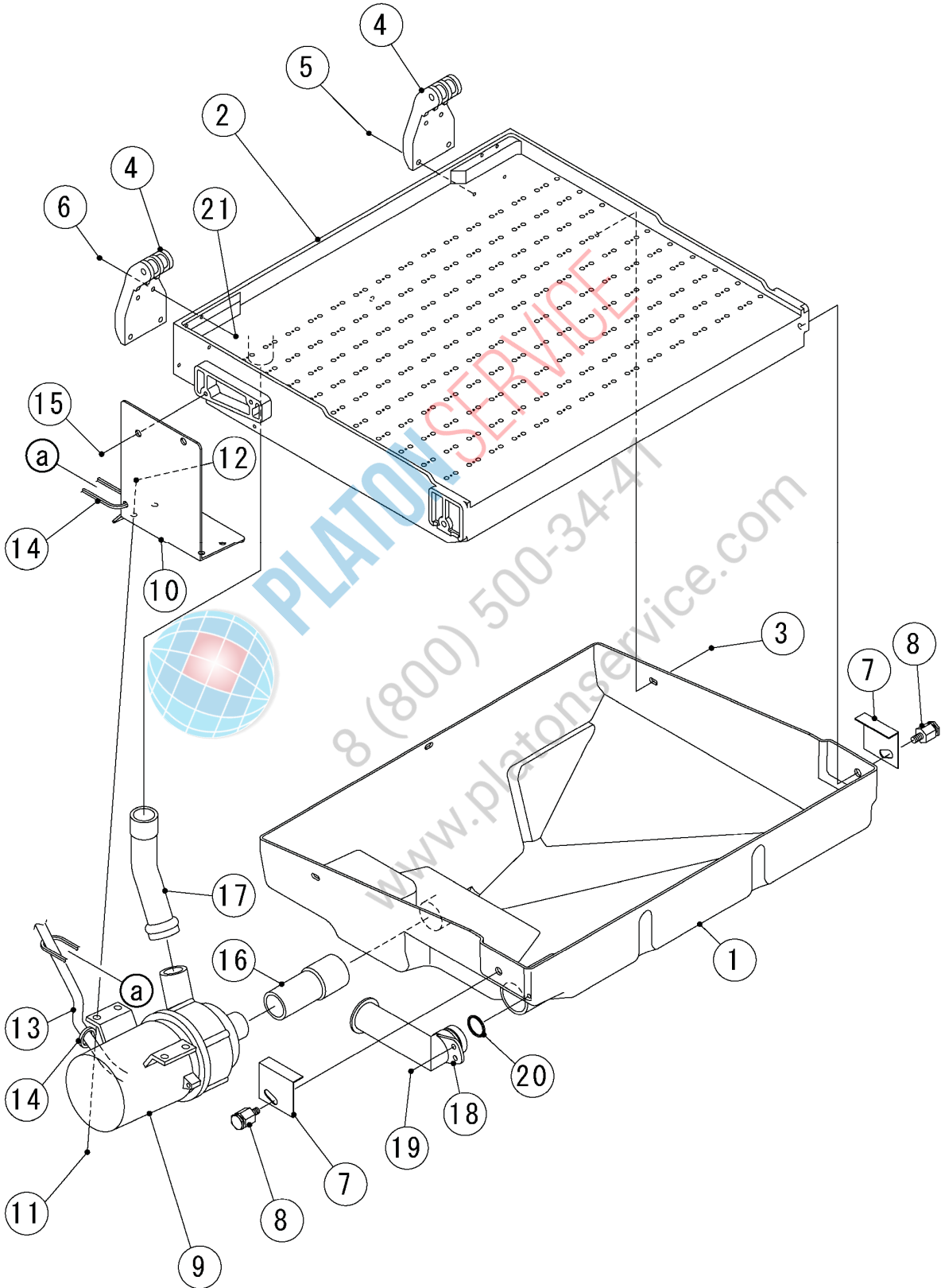

HE,GENERAL,KOREA

MODEL: IM-240ANE,-21,-23 IM-240AWNE,-21,-23,-17				TITLE: J.WATER PAN ASSY			
INDEX NO.	DESCRIPTION	MATERIAL OR MODEL NUMBER	PART NUMBER	REQ'D NUMBER			
				A-1 B-0	B-1 B-2	B-3 C-0	C-1,D-0 E-0,F-0
1	WATER PAN		1H0888-02	1	1	1	1
2	WATER PLATE		208020G01	1	1	1	1
		(240ANE-21) (240AWNE-21)	208484G01	1	1	1	1
		(240AWNE-17)	208484G02	-	-	-	1
3	TRUSS HEAD TAPPING SCREW T2		FT20406M0	3	3	3	3
	TRUSS HEAD MACHINE SCREW	(240ANE-21) (240AWNE-21) (240AWNE-17)	FST0408S0	3	3	3	3
4	WATER PAN HANGER		3H2059-01	2	2	2	2
5	TRUSS HEAD TAPPING SCREW T2		FT20416M0	4	4	4	4
	TRUSS HEAD MACHINE SCREW	(240ANE-21) (240AWNE-21) (240AWNE-17)	FST0420S0	4	4	4	4
6	TRUSS HEAD TAPPING SCREW T2		FT20425M0	4	4	4	4
	TRUSS HEAD MACHINE SCREW	(240ANE-21) (240AWNE-21) (240AWNE-17)	FST0425S0	4	4	4	4
7	BRACKET		402957-01	2	2	2	2
8	SCREW SPRING HOOK		4H2582G01	2	2	2	2
9	PUMP MOTOR	PMX-352BHZ1S	P02715-01	1	1	1	1
10	BRACKET - PUMP		4Y6617M01	1	1	1	1
11	HEX HEAD BOLT (SPRING WASHER AND FLAT WASHER)		FBK0412S0	4	4	4	4
12	FLANGE NUT		FNHF04S0	4	4	4	4
13	TUBE - SILICONE		4Y7388Z02	1	1	1	1
14	NYLON TIE	CV-100	7920-0002	2	2	2	2
15	TRUSS HEAD TAPPING SCREW T2		FT20516M0	2	2	2	2
	TRUSS HEAD MACHINE SCREW	(240ANE-21) (240AWNE-21) (240AWNE-17)	FST0516S0	2	2	2	2
16	SUCTION TUBE		4Y6641R01	1	1	1	1
17	DISCHARGE TUBE		4Y6642R01	1	1	1	1
18	PIPE - DRAIN		315530-01	1	1	1	1
19	TRUSS HEAD MACHINE SCREW		FST0410S0	1	1	1	1
20	O-RING		7611-G025	1	1	1	1
21	NUT	(240ANE-21) (240AWNE-21) (240AWNE-17)	FNH104S0	4	4	4	4

IM-240ANE (-21,-23)
IM-240AWNE(-21,-23,-17)

K. ACCESSORIES

(A-1) and later

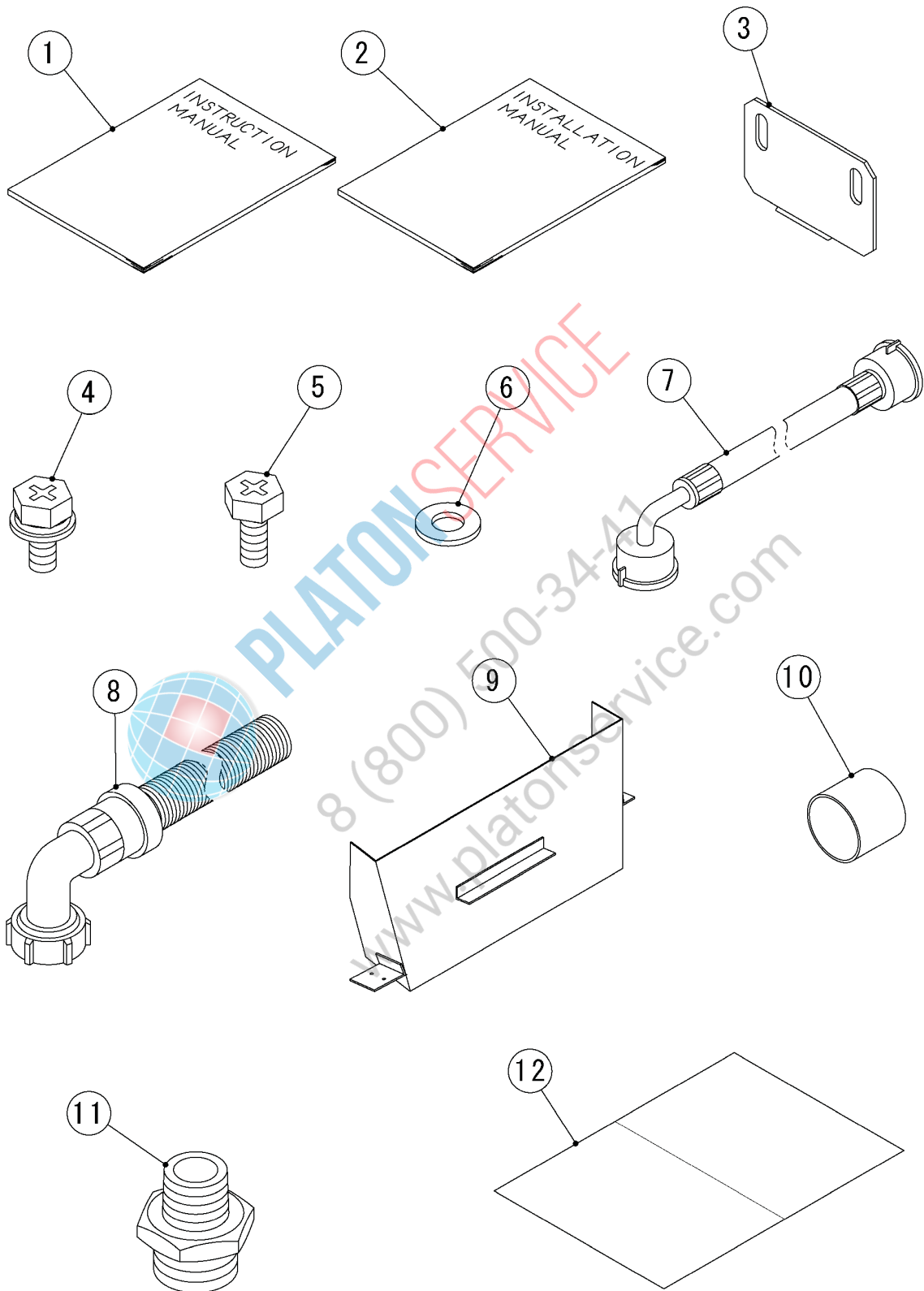

IM-240ANE (-21,-23)
IM-240AWNE(-21,-23,-17)

L. OPTIONAL PARTS

(A-1) and later

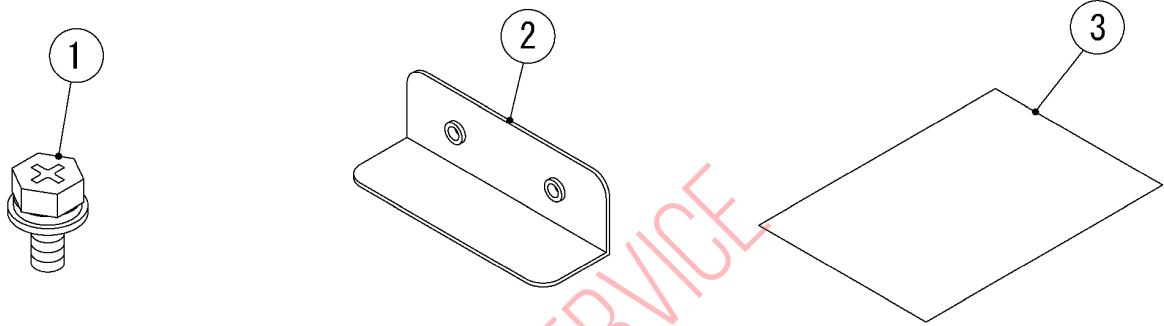

PLATON SERVICE

8 (800) 500-34-47

www.platonservice.com

HE,GENERAL,KOREA

MODEL: IM-240ANE,-21,-23 IM-240AWNE,-21,-23,-17		TITLE: L.OPTIONAL PARTS					
INDEX NO.	DESCRIPTION	MATERIAL OR MODEL NUMBER	PART NUMBER	REQ'D NUMBER			
				A-1 B-0	B-1 B-2	B-3 C-0	C-1,D-0 E-0,F-0
1	HEX HEAD BOLT (SPRING WASHER AND FLAT WASHER)		FBK0408S0	2	2	2	2
2	PLATE - ICECHUTE		4Y6284M01	1	1	1	1
3	INSTRUCTION SHEET		258216L01	1	1	1	1



PLATON SERVICE

8 (800) 500-34-47

www.platonservice.com